

# C804 SL Blank Set-Up Sheet

Capricorn RC

## Front

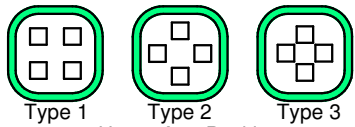

Upper Arm Position

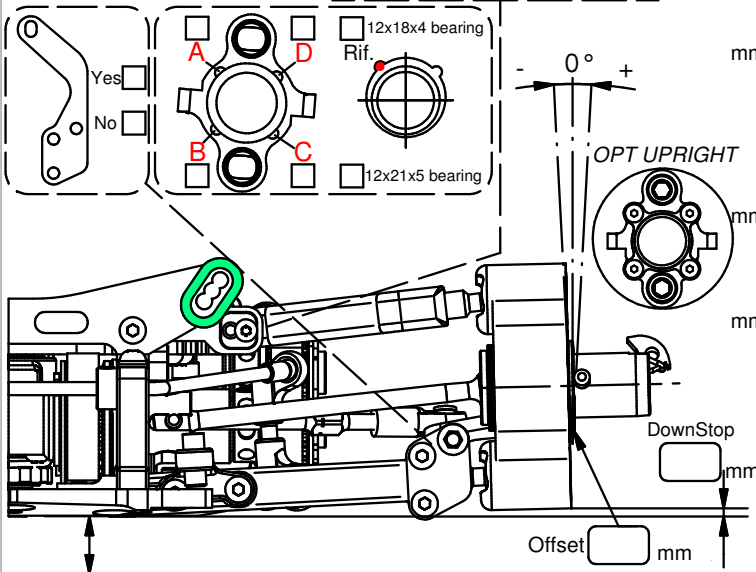

CAMBER		TOE / SIDE		WIDHT	
LEFT					
RIGHT					
WHEELBASE SHIM				Rear	Front
				<input type="checkbox"/>	<input type="checkbox"/>

ACKERMANN INSERTS						S.SAVER ARM	
8,5	9	10	11	12		<input type="checkbox"/>	<input type="checkbox"/>
						MONOLITHIC	

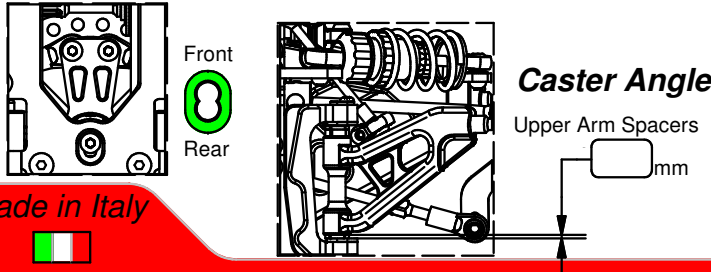

Made in Italy

FRONT		REAR			
LEFT	RIGHT	TYRES	LEFT		
BRAND		SHORE			
DIAMETER					
SHOCK ABSORBERS					
OIL		SPRING			
PISTON		HOLES Ø			
ANTI-ROLL BARS					
TYPE		Ø			
1 ST		SPUR GEAR		2 ND	
<input type="checkbox"/>	<input type="checkbox"/>	<input type="checkbox"/>	<input type="checkbox"/>	<input type="checkbox"/>	<input type="checkbox"/>
60	61	62	56	57	58
1 ST		PINION		2 ND	
<input type="checkbox"/>	<input type="checkbox"/>	<input type="checkbox"/>	<input type="checkbox"/>	<input type="checkbox"/>	<input type="checkbox"/>
18	19	23	24		
DRIVE TRAIN		UPRIGHT		FLEX	
MIDDLE AXLE PULLEY	<input type="checkbox"/>	<input type="checkbox"/>	Diff.	<input type="checkbox"/>	<input type="checkbox"/>
29	30			STD	OPT
				Rear	Yes
				No	
ENGINE					
TYPE		MUFFLER			
PLUG		NITRO			
BODY			TYPE		
SET-UP SHEET					
NAME					
DATE					
TEMP					
TRACK					
TRACTION					
RESULT					
BEST LAP					

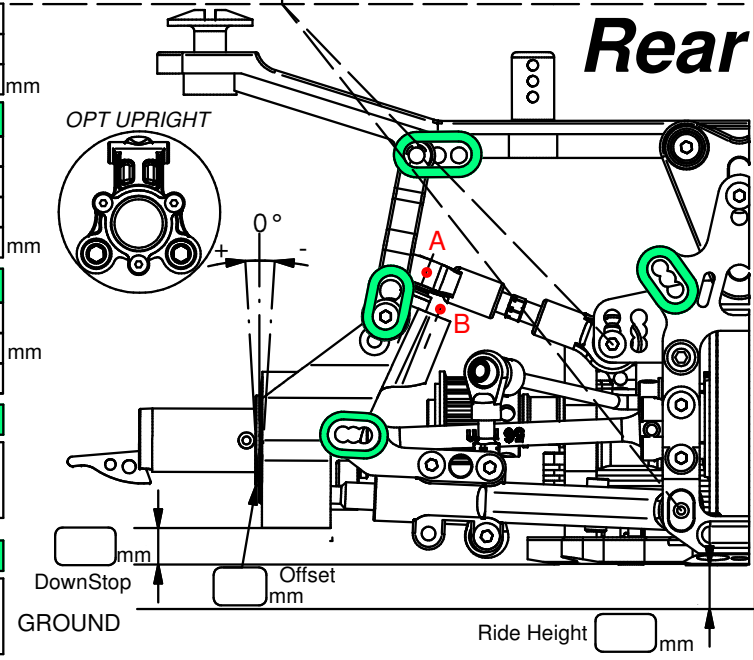
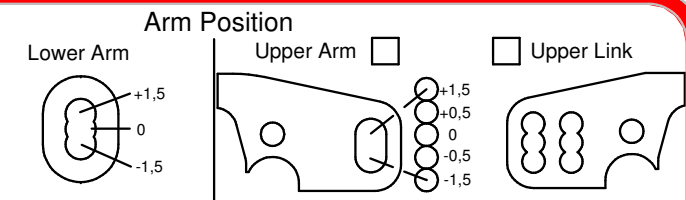

CAMBER		TOE / SIDE		WIDHT	
LEFT					
RIGHT					

ARM POSITION		UPPER ARM SHIM		BODY POSITION	
A	<input type="checkbox"/>	B	<input type="checkbox"/>		

BODY COLUMNS POSITION					
		Forward		Backwards	
Side weight strip			Battery Plate weight		
<input type="checkbox"/>	R	8,5 gr	F	<input type="checkbox"/>	gr
			Type		
Additional notes					