

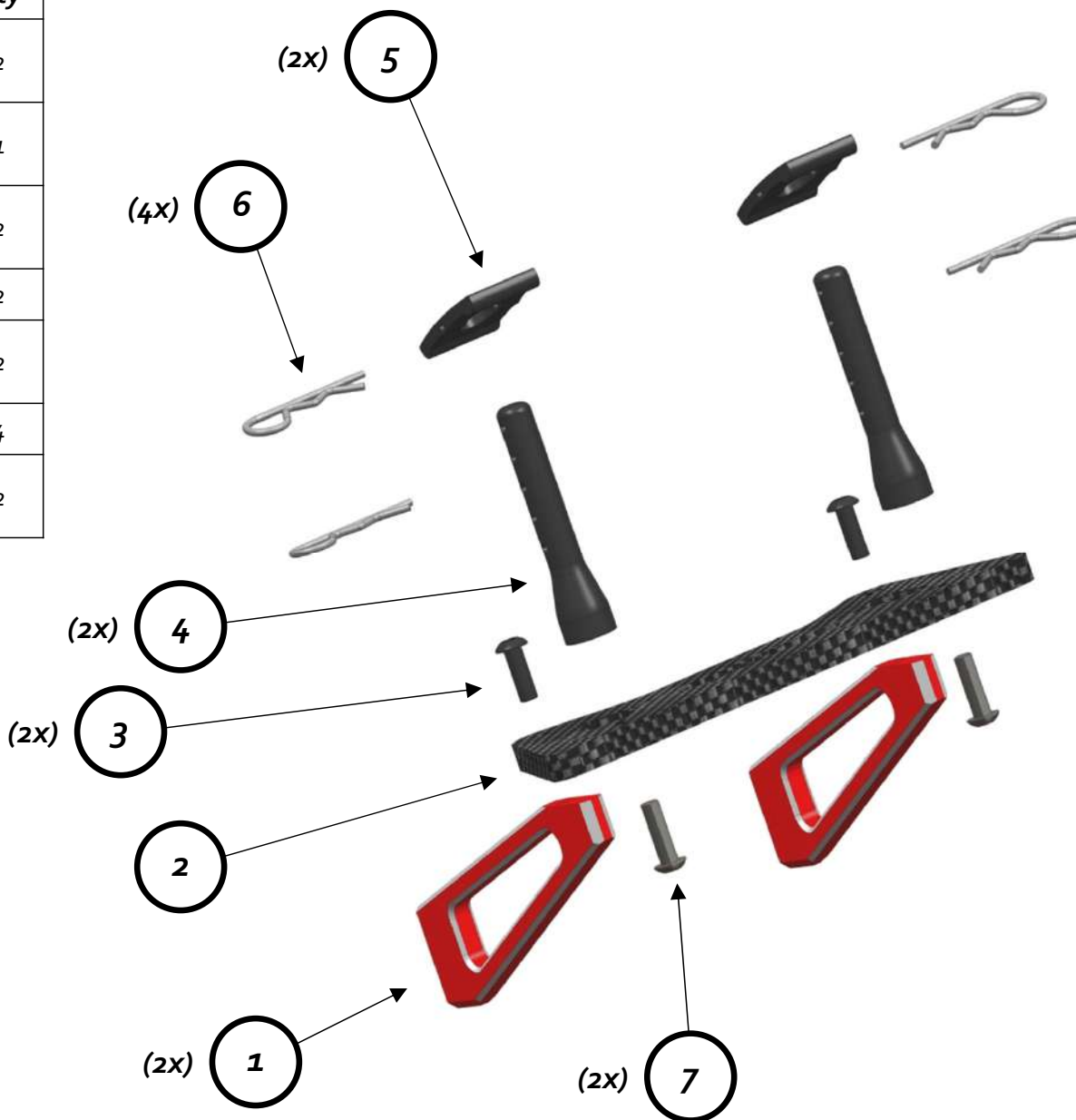

REAR BODY HOLDER

#	Code	Part Name	Qty
1	Cap 4024	Rear Body Holder Extension	2
2	Cap 4107	Rear Body Holder Plate	1
3	Cap 4145	Button Head Cap Screw M4x12	2
4	Cap 4081-K	Body Holder Column	2
5	Cap 4081-K	Body Holder Column Support	2
6	Cap clips1	Body Clip XL	4
7	Cap 4116	Button Head Cap Screw M4x14	2





FRONT BODY HOLDER

#	Code	Part Name	Qty
1	Cap 4111	Front Body Holder	1
2	Cap 4081-K	Body Holder Column	2
3	Cap 4081-K	Body Holder Column Support	2
4	Cap clips1	Body Clip XL	4
5	Cap 4116	Button Head Cap Screw M4x14	2

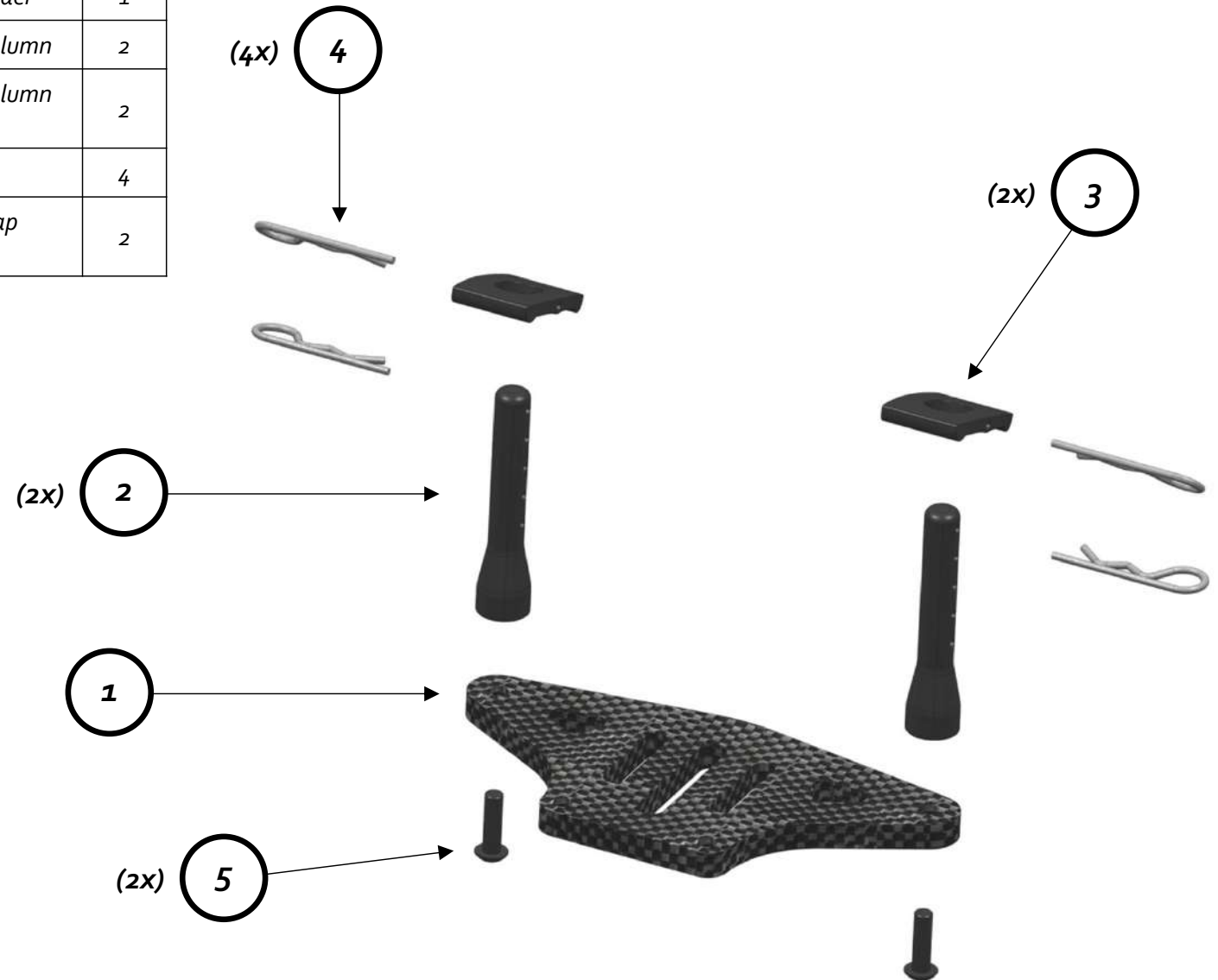



BUMPER

#	Code	Part Name	Qty
1	Cap 4160	Bumper Support	1
2	Cap 4080	Bumper Foam	1
3	Cap 4038	Bumper Fixation	1
4	Cap 4083	Bumper Holder Column	4
5	Cap 27002	Clip	4
6	Cap 4113	Countersunk Head Cap Screw M4x16	4

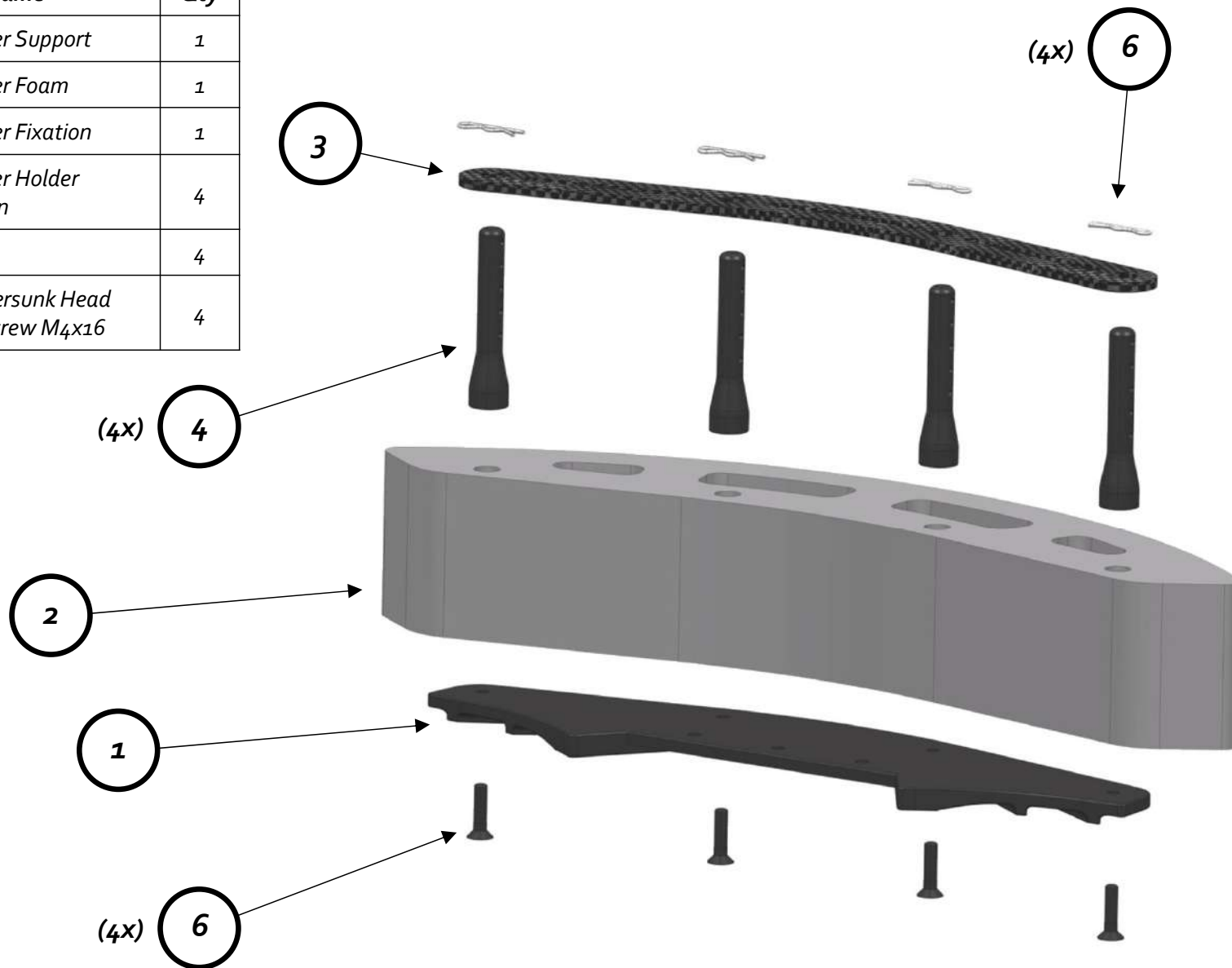

FRONT BULKHEAD



#	Code	Part Name	Qty
1	Cap 4005	Front Bulkhead	2
2	Cap 4152	Front Upper Bulkhead Plate	2
3	Cap 4153	Front Bulkhead Plate Stiffener	1
4	Cap 4156	Button Head Cap Screw M4x16	4

(4X) 4



3



(2X) 2



CASTER SETUP

Select the front upper bulkhead plate holes to be coupled with the front bulkhead pins according to the desired caster

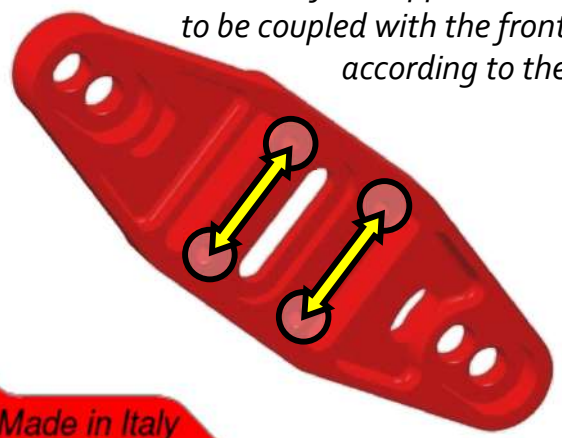

Coupling

Coupling

(2X) 1

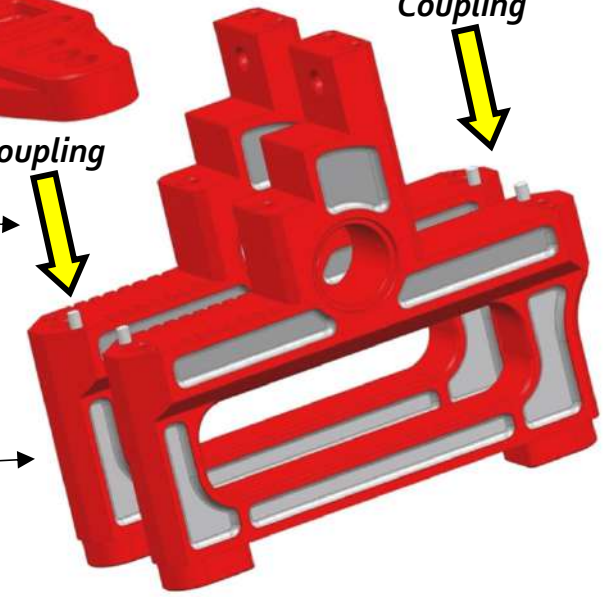

FRONT BULKHEAD



#	Code	Part Name	Qty
1	Cap 4112	Front Shock Tower	1
2	Cap 2145	Countersunk Head Cap Screw M4x12	2
3	Cap 4157	Shock Absorber Column	2
4	Cap 4163	Button Head Cap Screw Flange M3x25	2
5	Cap 4137	Bearing Flange Shielded 8x12x3.5 SMF128 ZZ	2

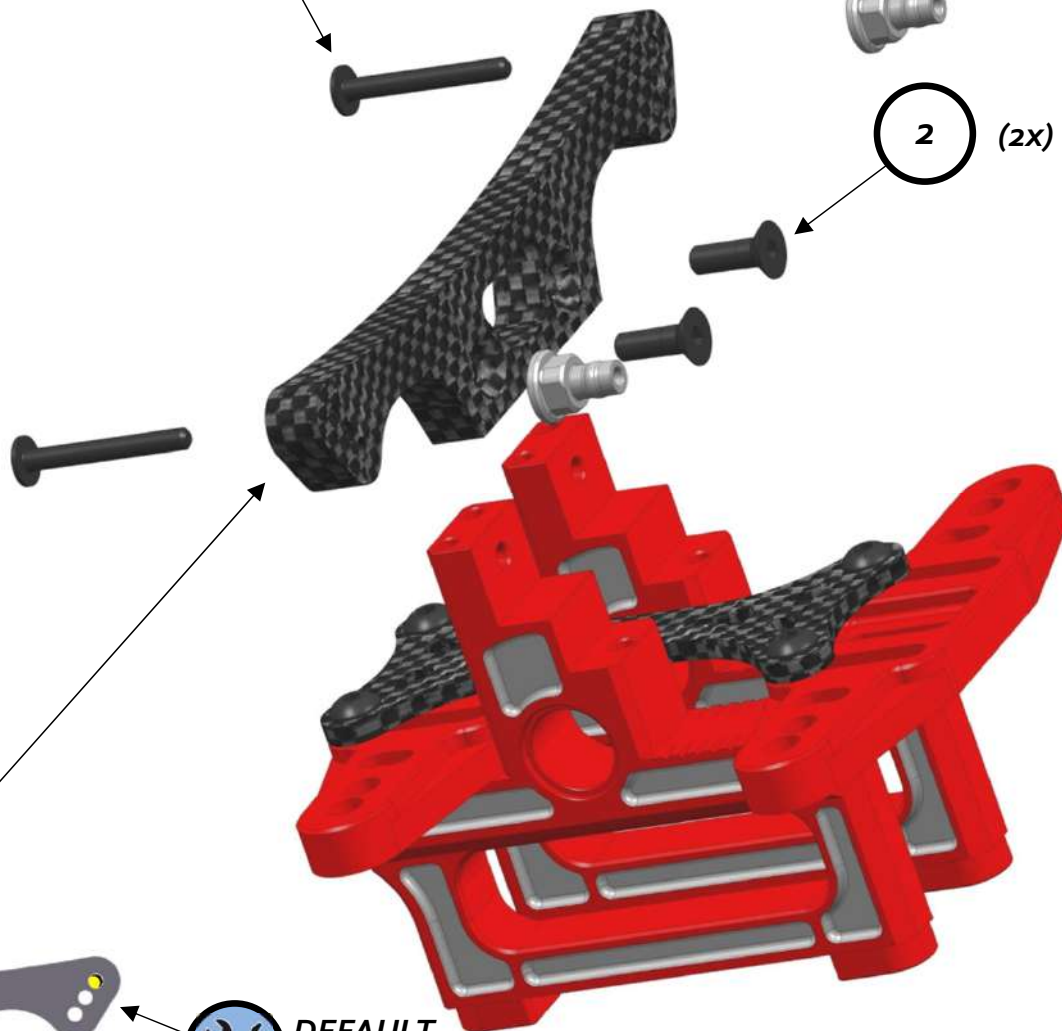
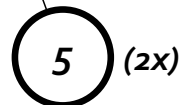
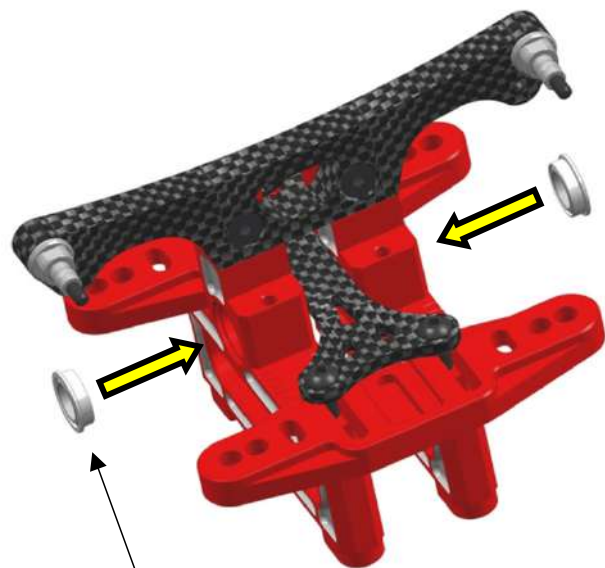



REAR BULKHEAD

#	Code	Part Name	Qty
1	Cap 4006	Rear Bulkhead Engine Side	1
2	Cap 4007	Rear Bulkhead	1
3	Cap 4027	Bearing 15x24x5 61802 ZZ	2
4	Cap 4011	Differential Bearing Bushing	2
5	Cap 4008	Rear Upper Bulkhead	2
6	Cap 4130	Cylindrical Head Cap Screw M4x12	4

DIFFERENTIAL NOT INCLUDED

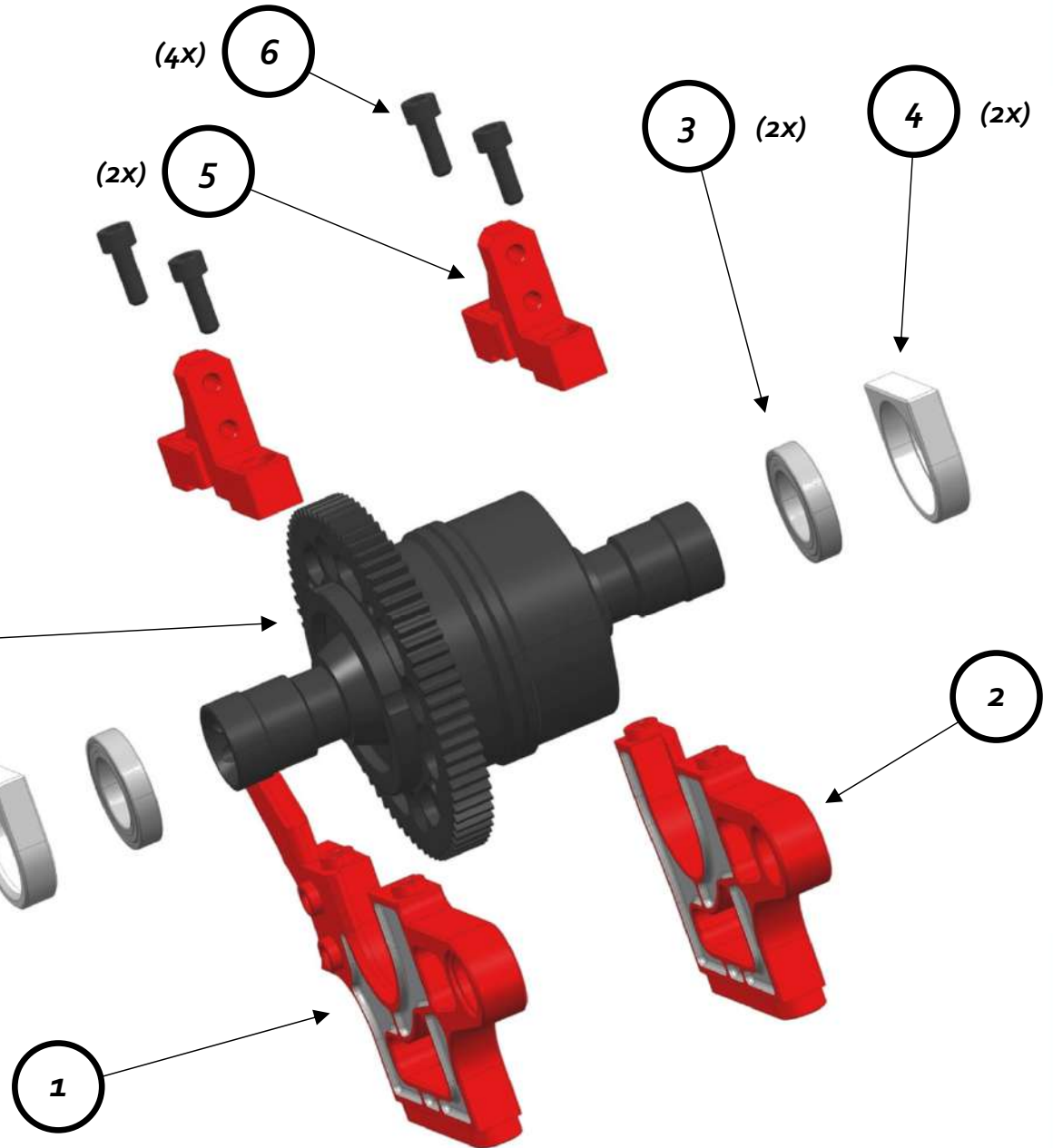



REAR BULKHEAD

#	Code	Part Name	Qty
1	Cap 4109	Rear Shock Tower	1
2	Cap 2145	Countersunk Head Cap Screw M4x12	2
3	Cap 4157	Shock Absorber Column	2
4	Cap 4163	Button Head Cap Screw Flange M3x25	2
5	Cap 4055	Rear Upper Suspension Arm Column	2
6	Cap 4145	Button Head Cap Screw M4x12	2
7	Cap 4099	Column M4 21mm	2
8	Cap 4166	Countersunk Head Cap Screw M4x10	2

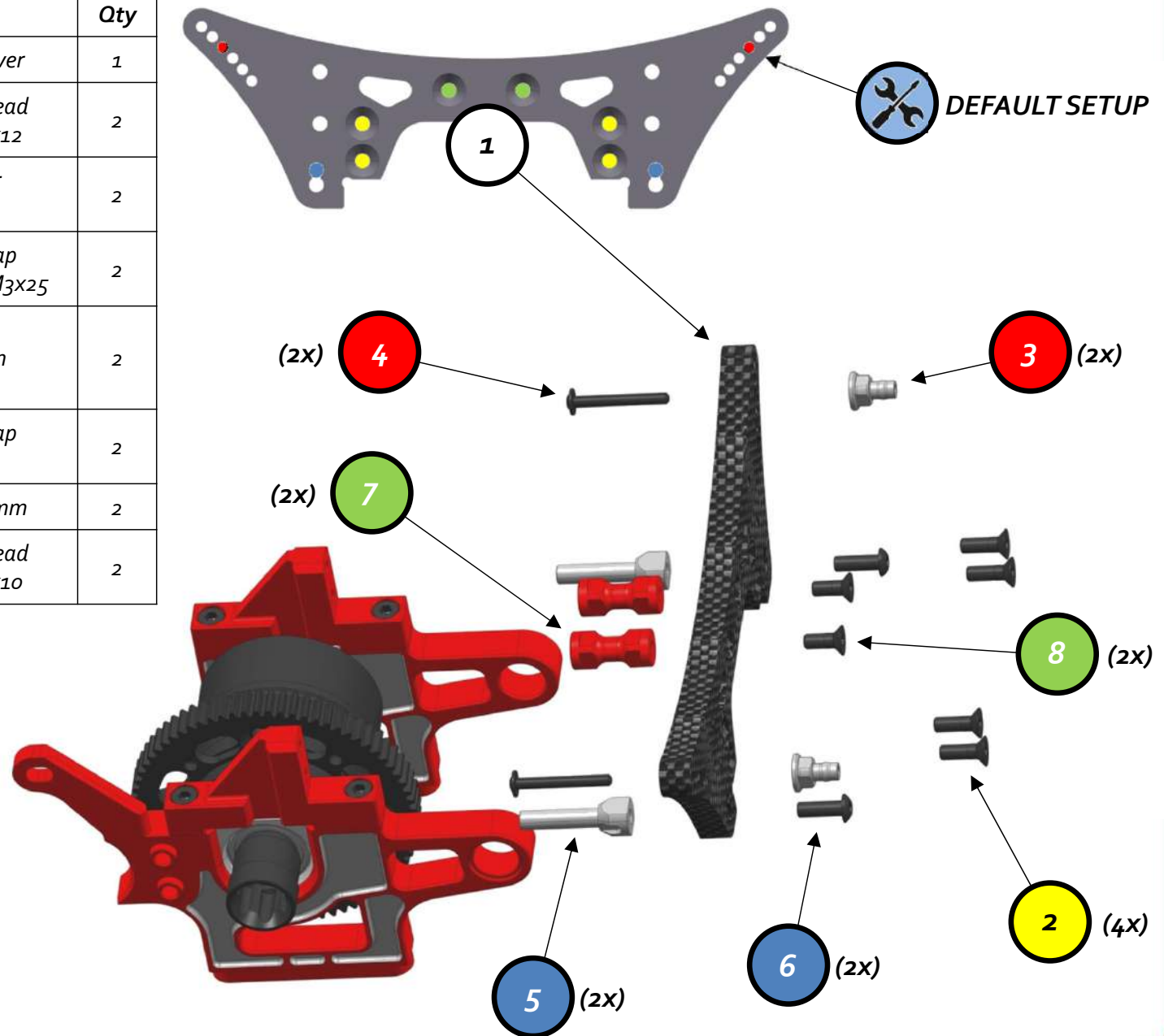



REAR BULKHEAD

#	Code	Part Name	Qty
1	Cap 4117	Countersunk Head Cap Screw M4x14	4
2	Cap 4137	Bearing Flange Shielded 8x12x3.5 SMF128 ZZ	2

REAR BODY
HOLDER

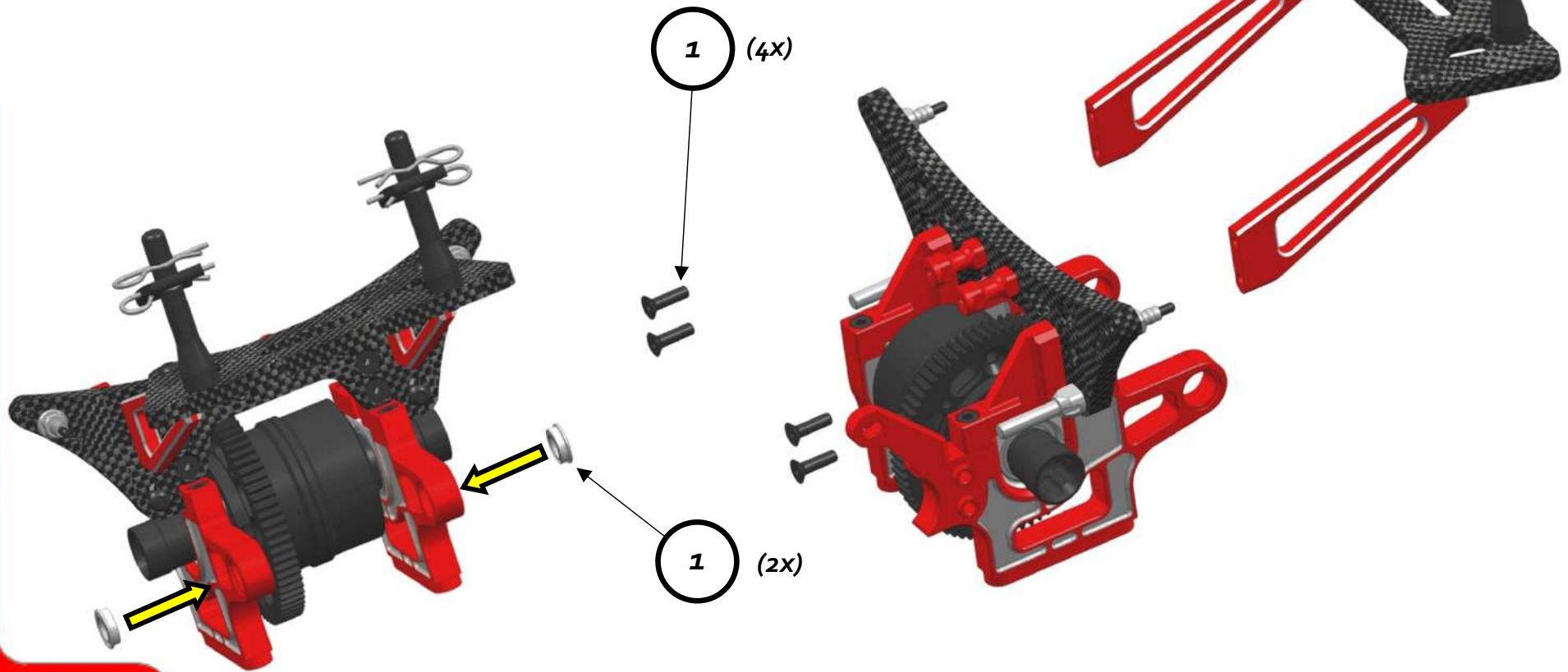

**FRONT LOWER
SUSPENSION ARM**



#	Code	Part Name	Qty
1	Cap 4003	Suspension Pivot Sphere	4
2	Cap 4016	Front Lower Suspension Arm	2
3	Cap 4014	Suspension Pivot Bushing	4
4	Cap 4085	Shaft Seeger-Rings 14mm	4

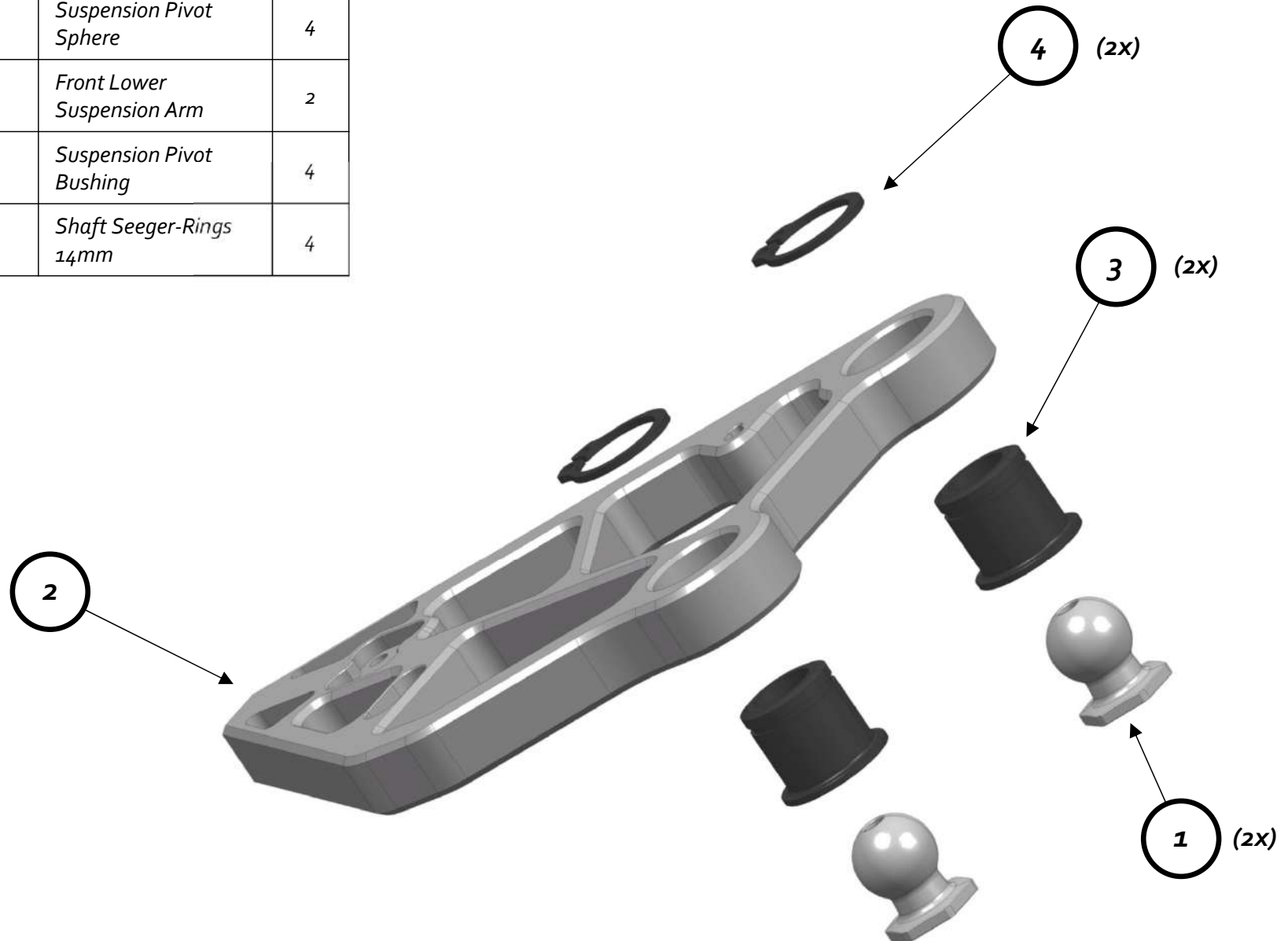

FRONT LOWER SUSPENSION ARM

Capricorn RC
BUILD **2X** L/R



#	Code	Part Name	Qty
1	Cap 4018	Shock Absorber Extension	2
2	Cap 17023	Button Head Cap Screw M3x10	4
3	Cap 4019	Suspension Arm Sway-bar Holder	2
4	Cap 17032	Button Head Cap Screw M3x8	4
5	Cap 4079	Suspension Arm Sway-bar Pivotball 7.0mm	2
6	Cap 17031	Countersunk Head Cap Screw M3x8	2

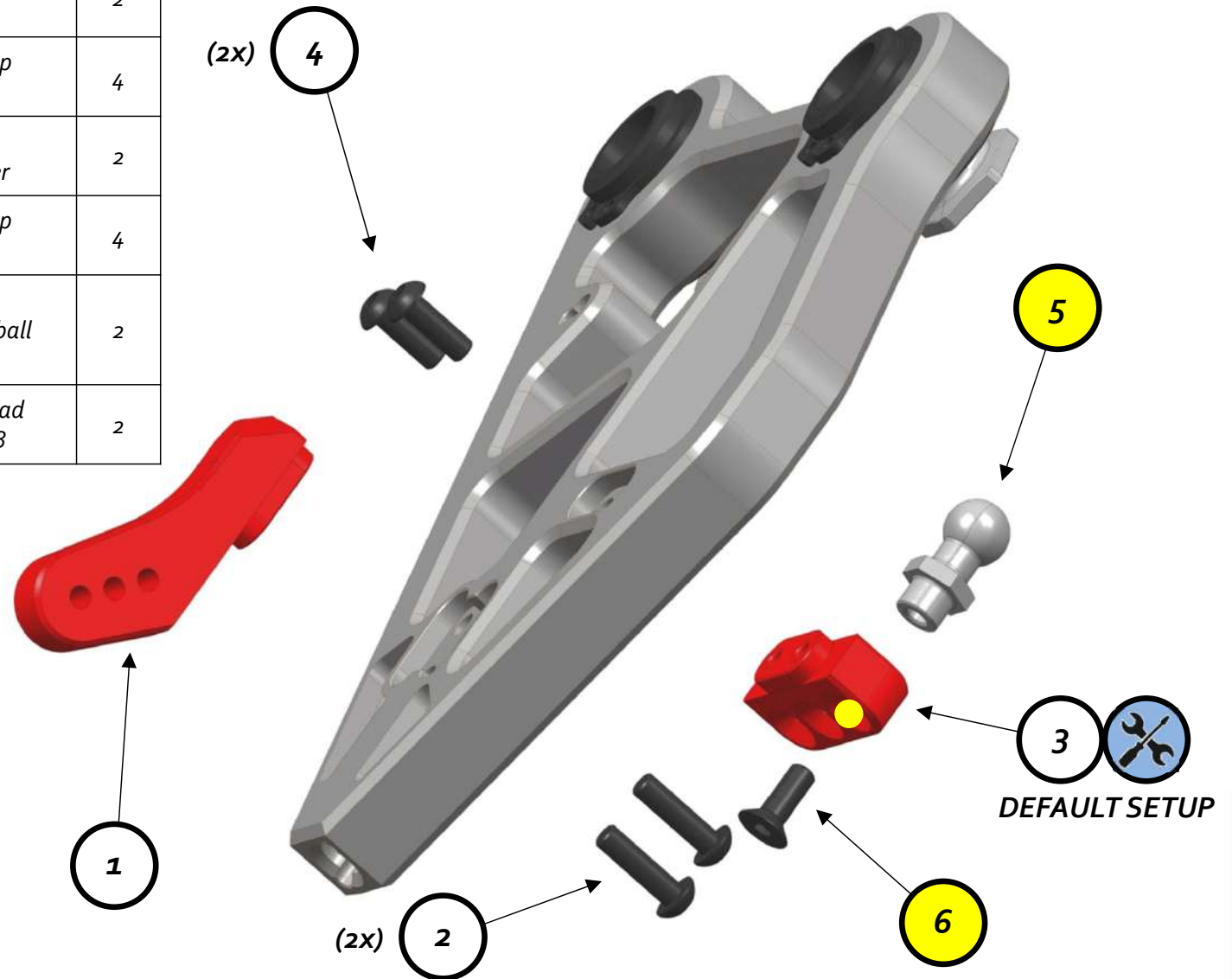

FRONT LOWER SUSPENSION ARM



#	Code	Part Name	Qty
1	Cap 4087	Grub Screw M4x18	2
2	Cap 4086	Nylon Wire	6

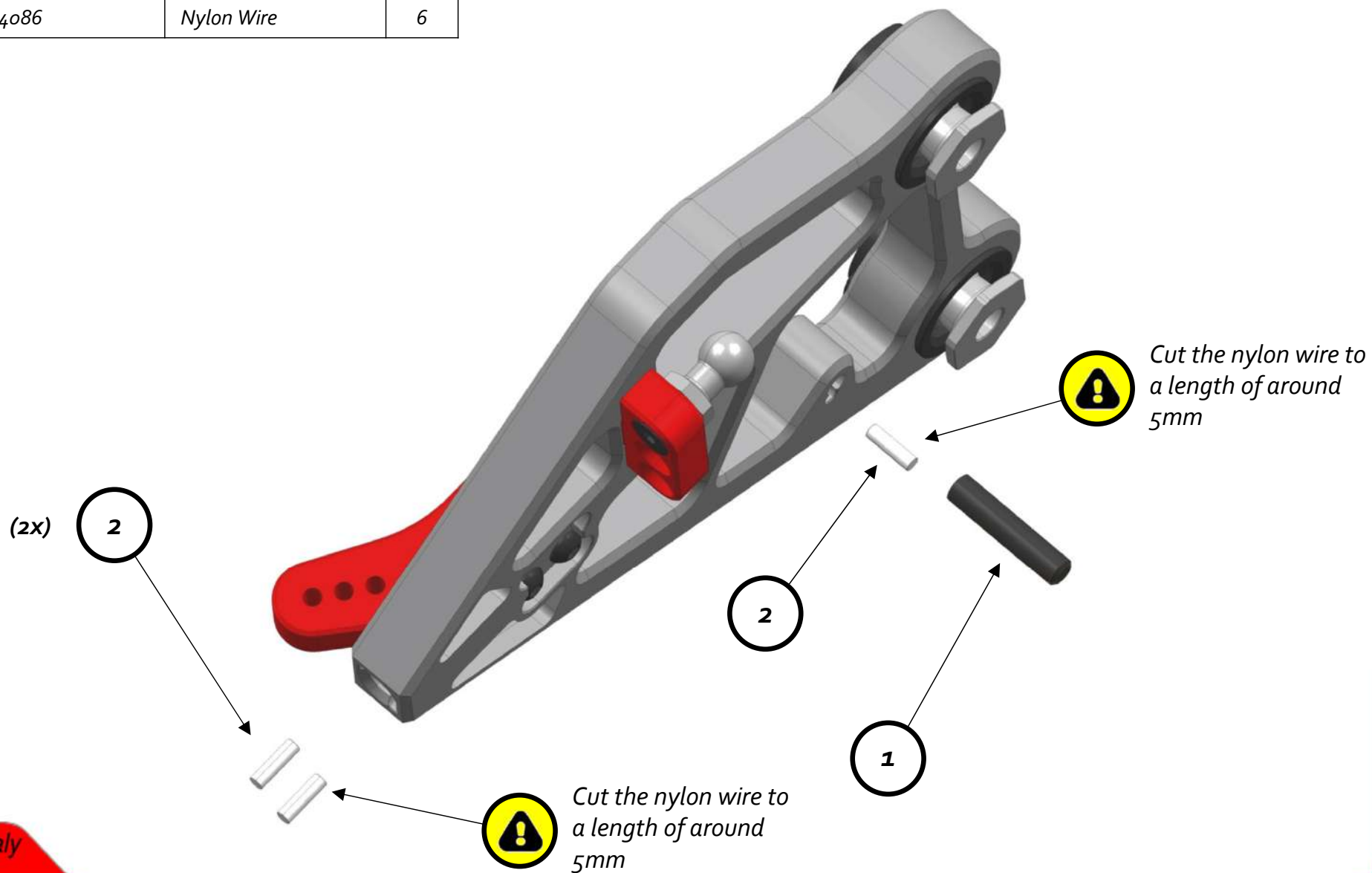

**REAR LOWER
SUSPENSION ARM**



#	Code	Part Name	Qty
1	Cap 4003	Suspension Pivot Sphere	4
2	Cap 4015	Rear Lower Suspension Arm	2
3	Cap 4014	Suspension Pivot Bushing	4
4	Cap 4085	Shaft Seeger-Rings 14mm	4

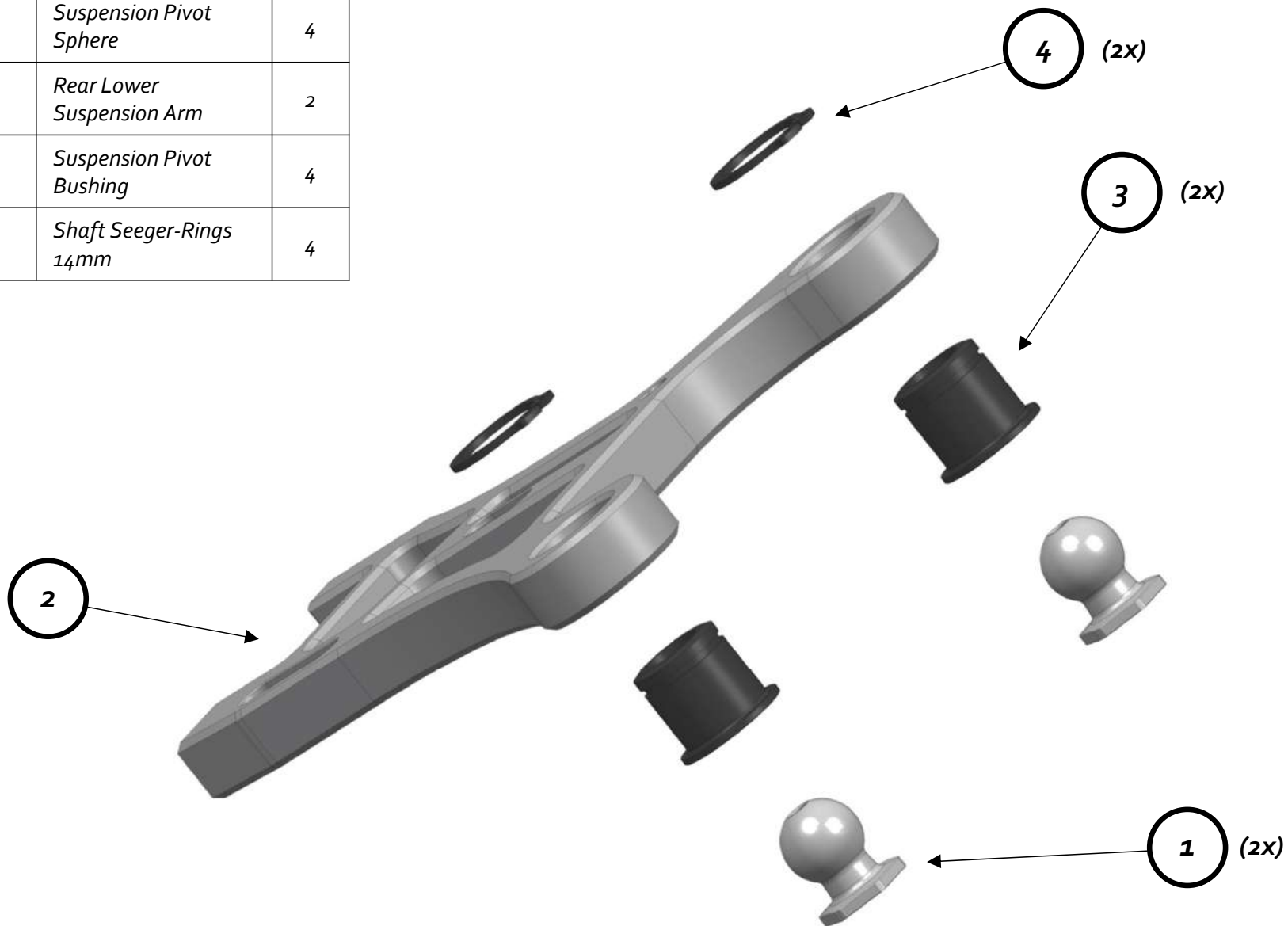

**REAR LOWER
SUSPENSION ARM**



#	Code	Part Name	Qty
1	Cap 4018	Shock Absorber Extension	2
2	Cap 17023	Button Head Cap Screw M3x10	4
3	Cap 4019	Suspension Arm Sway-bar Holder	2
4	Cap 17032	Button Head Cap Screw M3x8	4
5	Cap 4079	Suspension Arm Sway-bar Pivotball 7.0mm	2
6	Cap 17031	Countersunk Head Cap Screw M3x8	2

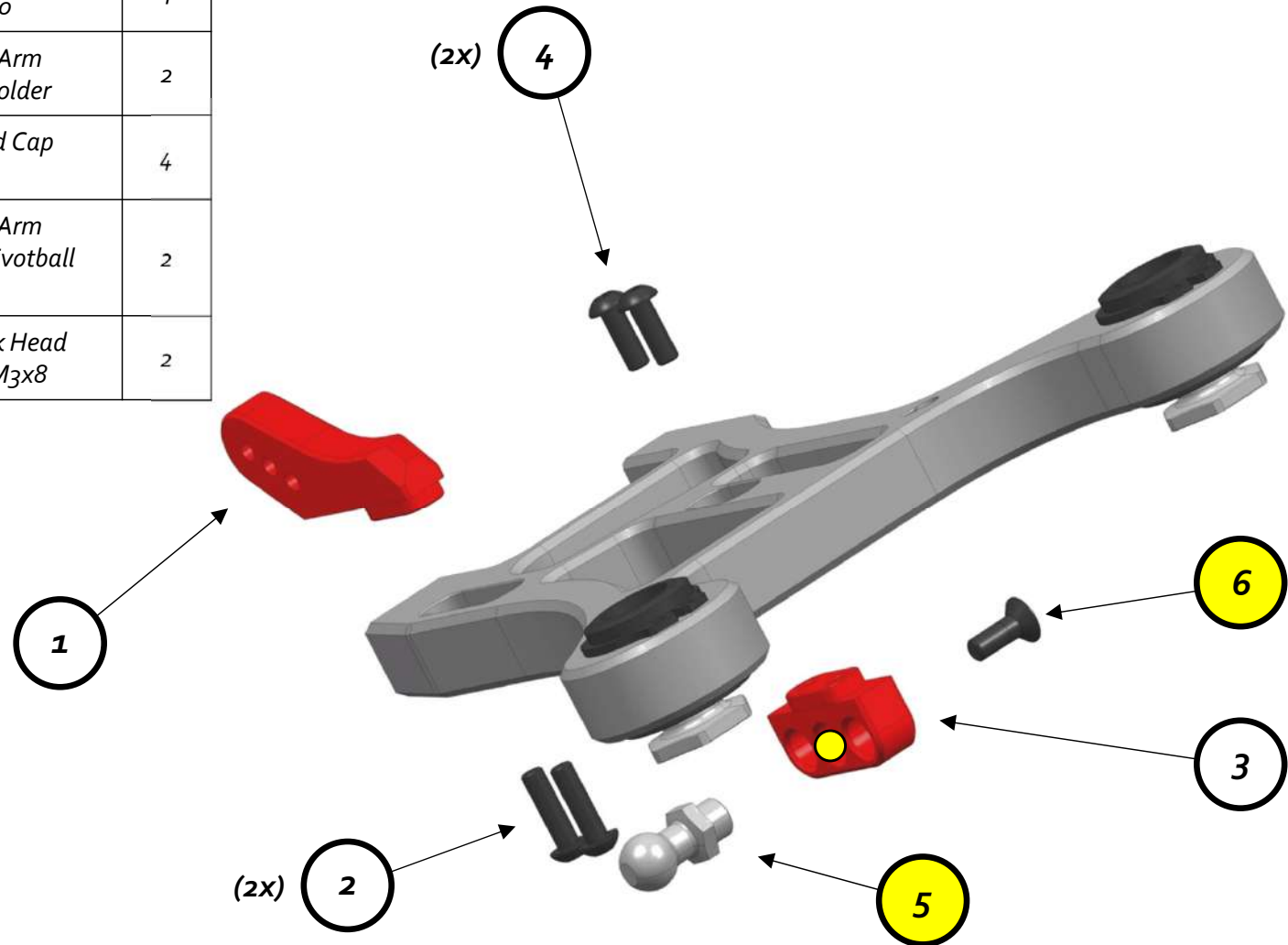

REAR LOWER
SUSPENSION ARM



#	Code	Part Name	Qty
1	Cap 4087	Grub Screw M4x18	2
2	Cap 4086	Nylon Wire	10

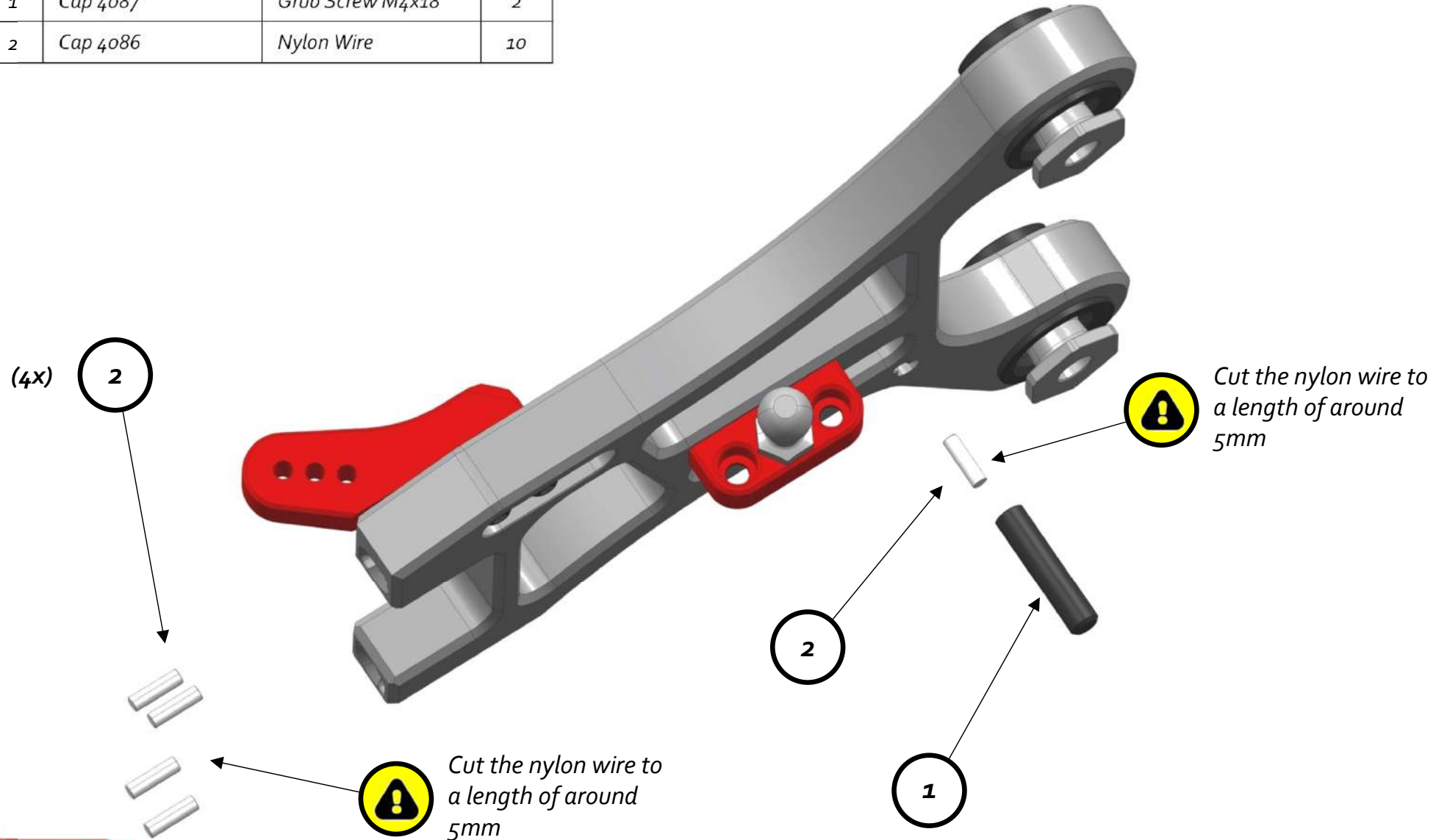

**FRONT UPPER
SUSPENSION ARM**



#	Code	Part Name	Qty
1	Cap 4003	Suspension Pivot Sphere	4
2	Cap 4017	Front Upper Suspension Arm	2
3	Cap 4014	Suspension Pivot Bushing	4
4	Cap 4085	Shaft Seeger-Rings 14mm	4
5	Cap 4086	Nylon Wire	4

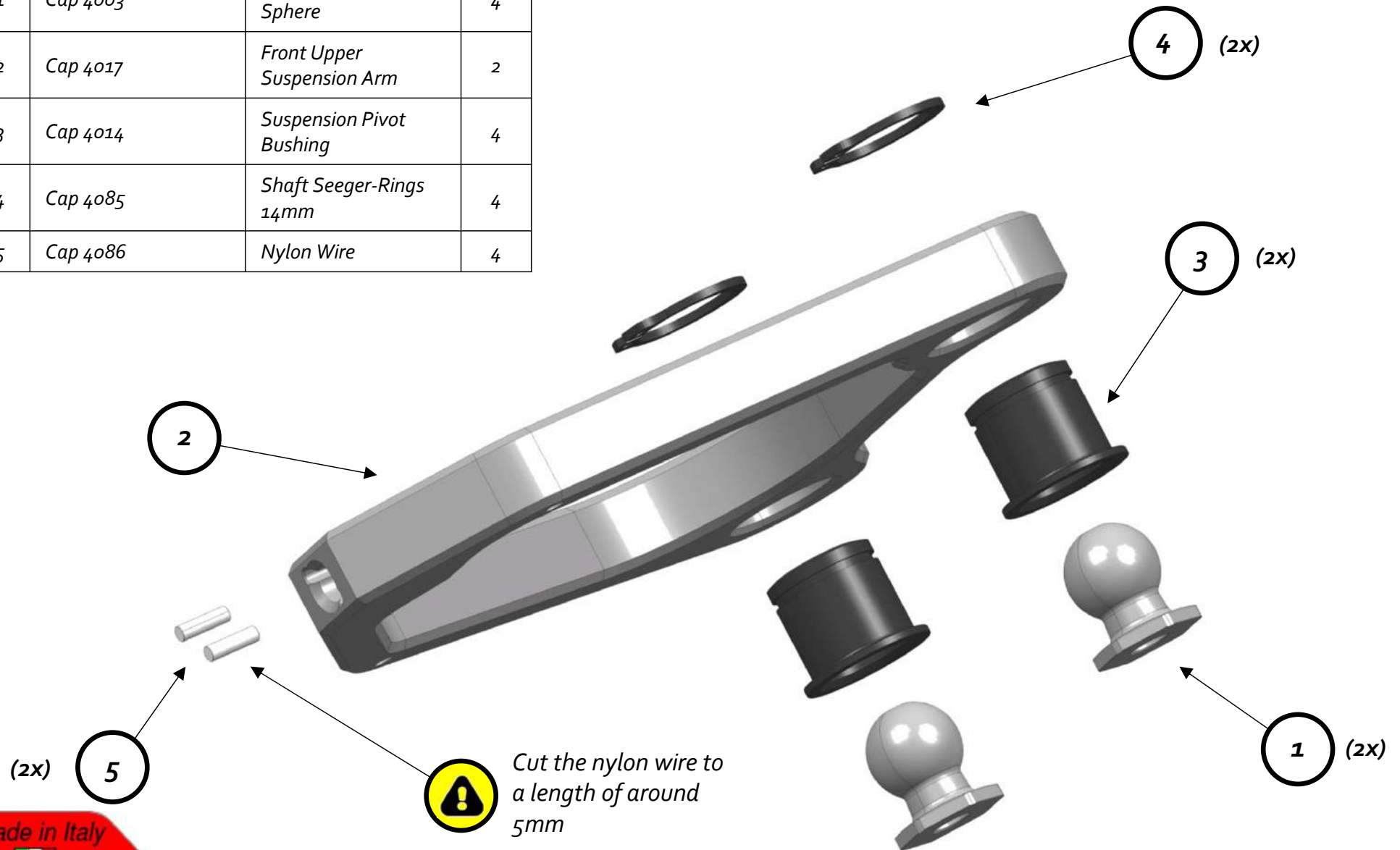

**REAR UPPER
SUSPENSION ARM**



#	Code	Part Name	Qty
1	Cap 4123	Rod End Ball Joint Right Thread	2
2	Cap 4124	Rod End Ball Joint Left Thread	2
3	Cap 4125	Turnbuckles M5x40	2
4	Cap 4126	Flange Nut Self-Locking M5 Right Thread	2
5	Cap 4127	Flange Nut Self-Locking M5 Left Thread	2

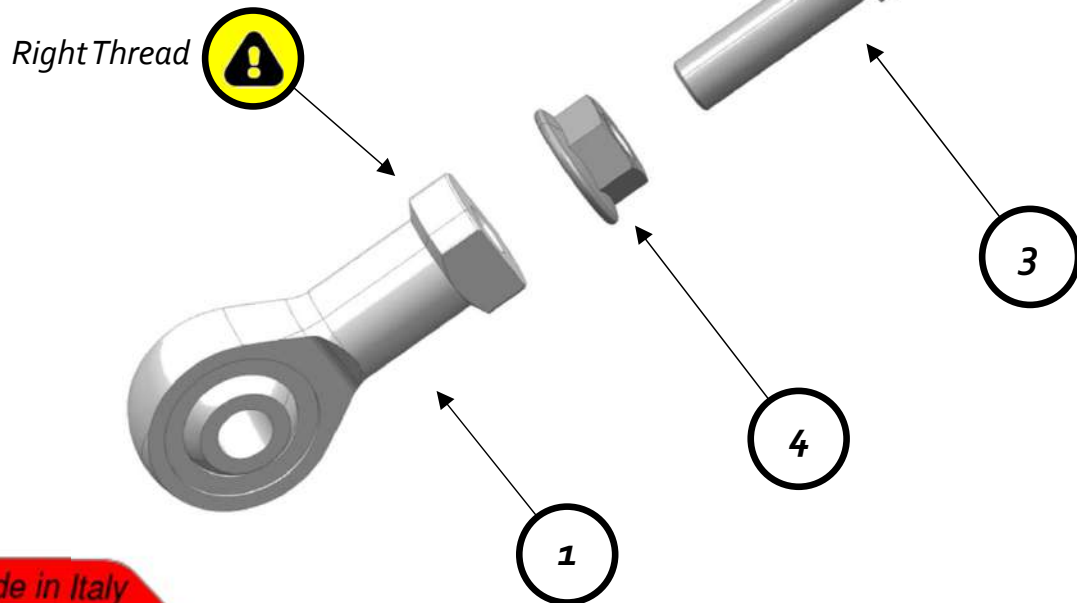
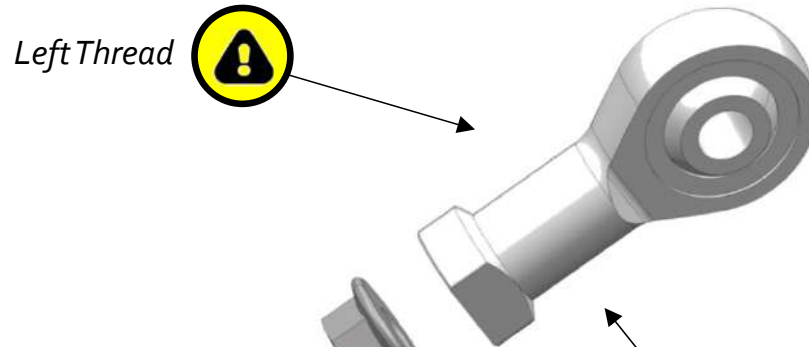

DEFAULT SETUP
Around 20.0mm

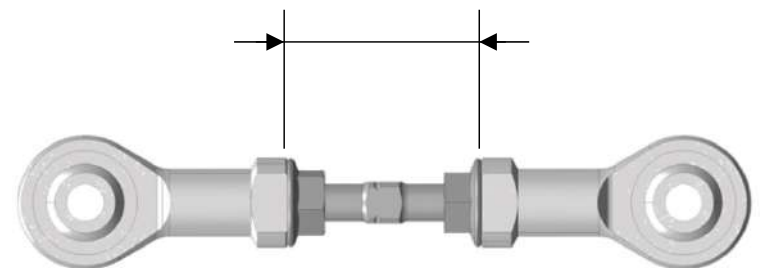

FRONT LOWER SUSPENSION ARMS MOUNTING



#	Code	Part Name	Qty
1	Cap 4012	Suspension Pivot Sphere Screw	4
2	Cap 4013	Suspension Pivot Sphere Shim 5x13x1	8
3	Cap 4002	Chassis	1



WHEELBASE SETUP

- Short
- Long

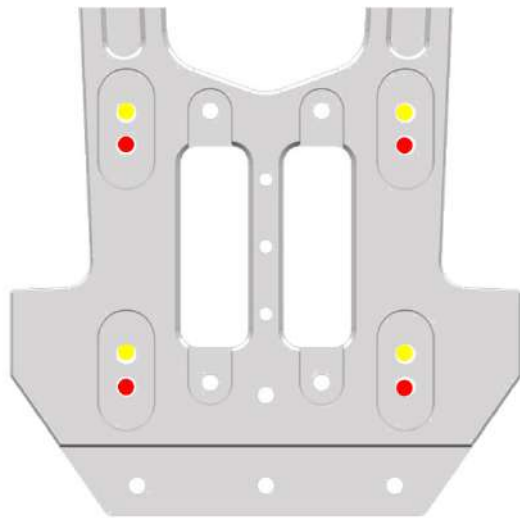

LEFT FRONT LOWER
SUSPENSION ARM

RIGHT FRONT LOWER
SUSPENSION ARM

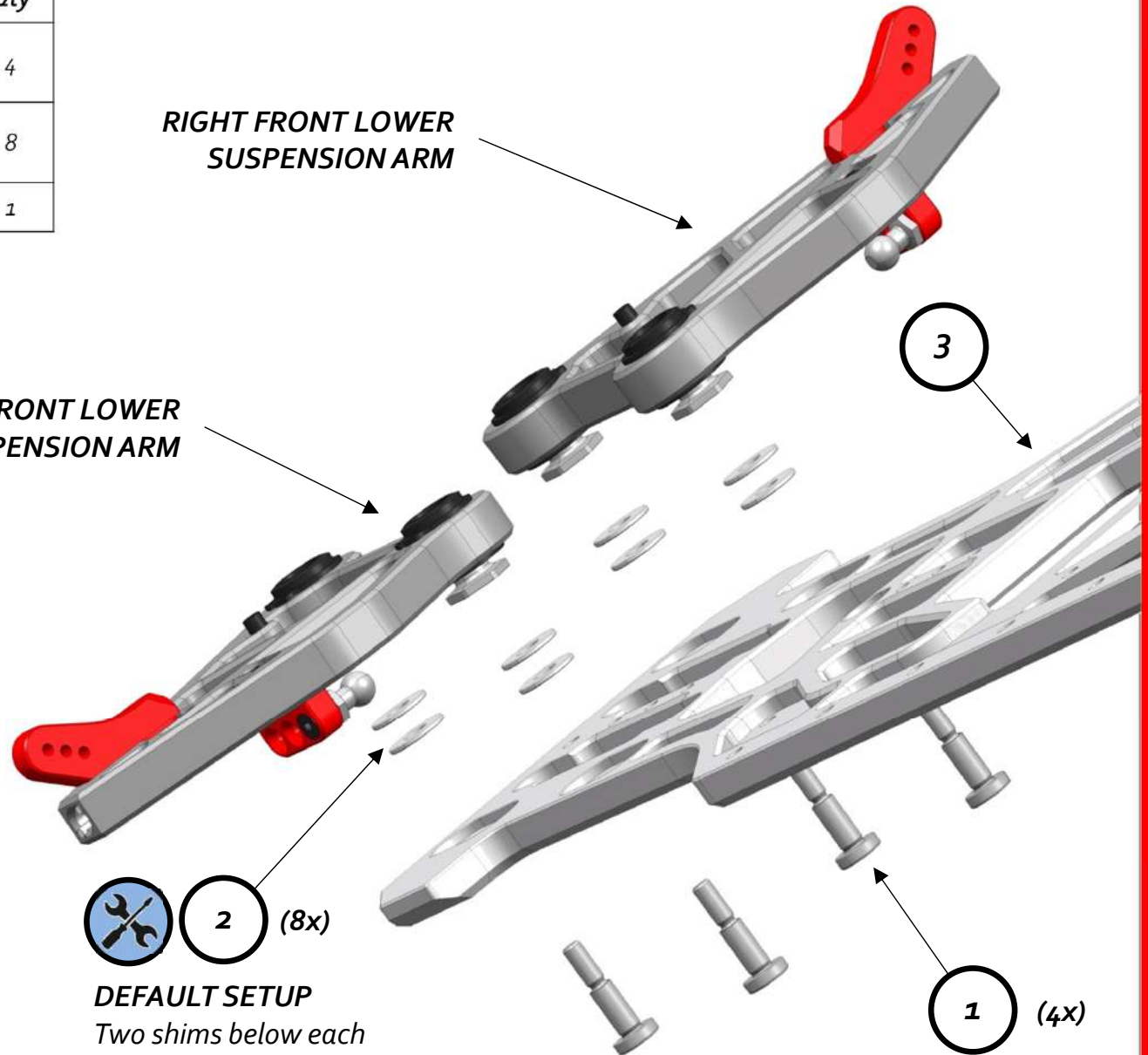

2 (8x)

DEFAULT SETUP
Two shims below each
suspension pivot sphere

1 (4x)



REAR LOWER SUSPENSION ARMS MOUNTING



#	Code	Part Name	Qty
1	Cap 4161	Suspension Pivot Sphere Screw Short	4

LEFT REAR LOWER
SUSPENSION ARM

RIGHT REAR LOWER
SUSPENSION ARM

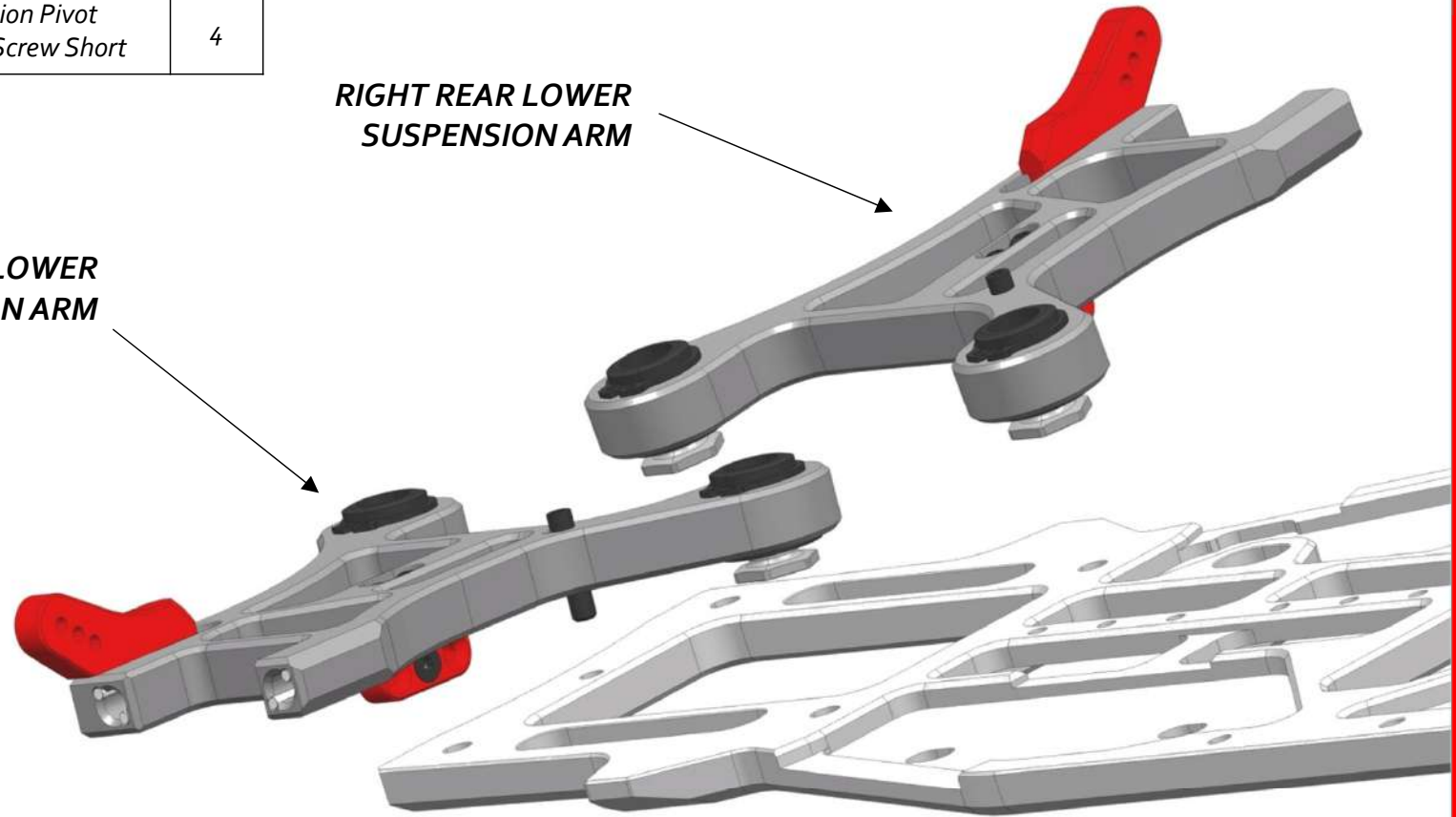

(4x) **1**



FRONT UPPER SUSPENSION ARMS MOUNTING



#	Code	Part Name	Qty
1	Cap 4013	Suspension Pivot Sphere Shim 5x13x1	6
2	Cap 4012	Suspension Pivot Sphere Screw	2
3	Cap 4161	Suspension Pivot Sphere Screw Short	2

RIGHT FRONT UPPER
SUSPENSION ARM

LEFT FRONT UPPER
SUSPENSION ARM

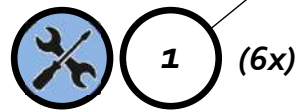

ANTI-DIVE SETUP

Increase or decrease the number of shims according to the desired anti-dive effect

FRONT BULKHEAD

(2x)

2

3

(2x)



FRONT BULKHEAD MOUNTING



#	Code	Part Name	Qty
1	Cap 4117	Countersunk Head Cap Screw M4x14	4

FRONT BULKHEAD

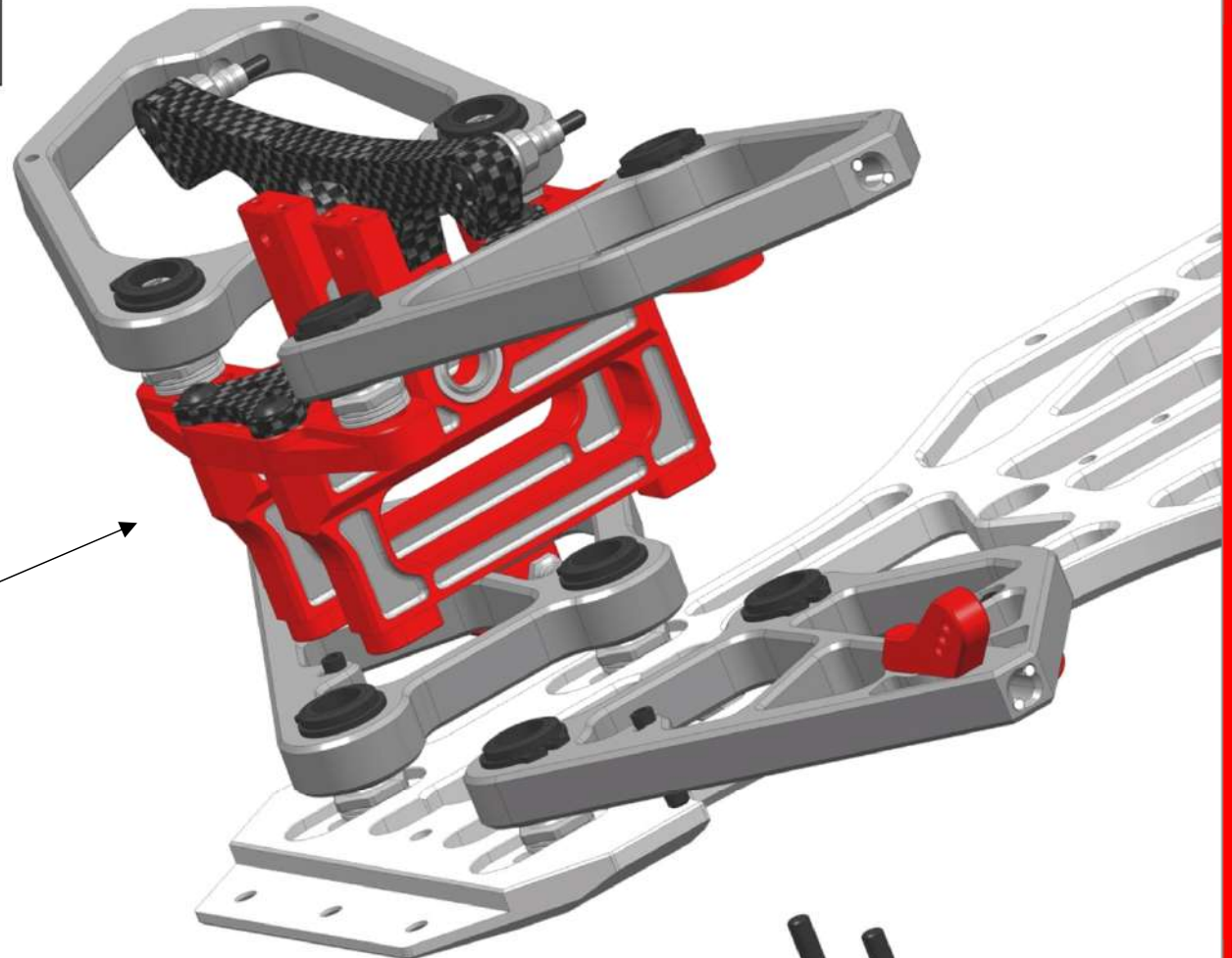
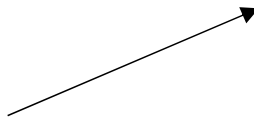

(4X)

1



REAR BULKHEAD MOUNTING



#	Code	Part Name	Qty
1	Cap 4117	Countersunk Head Cap Screw M4x14	4

REAR BULKHEAD

(4x) 1

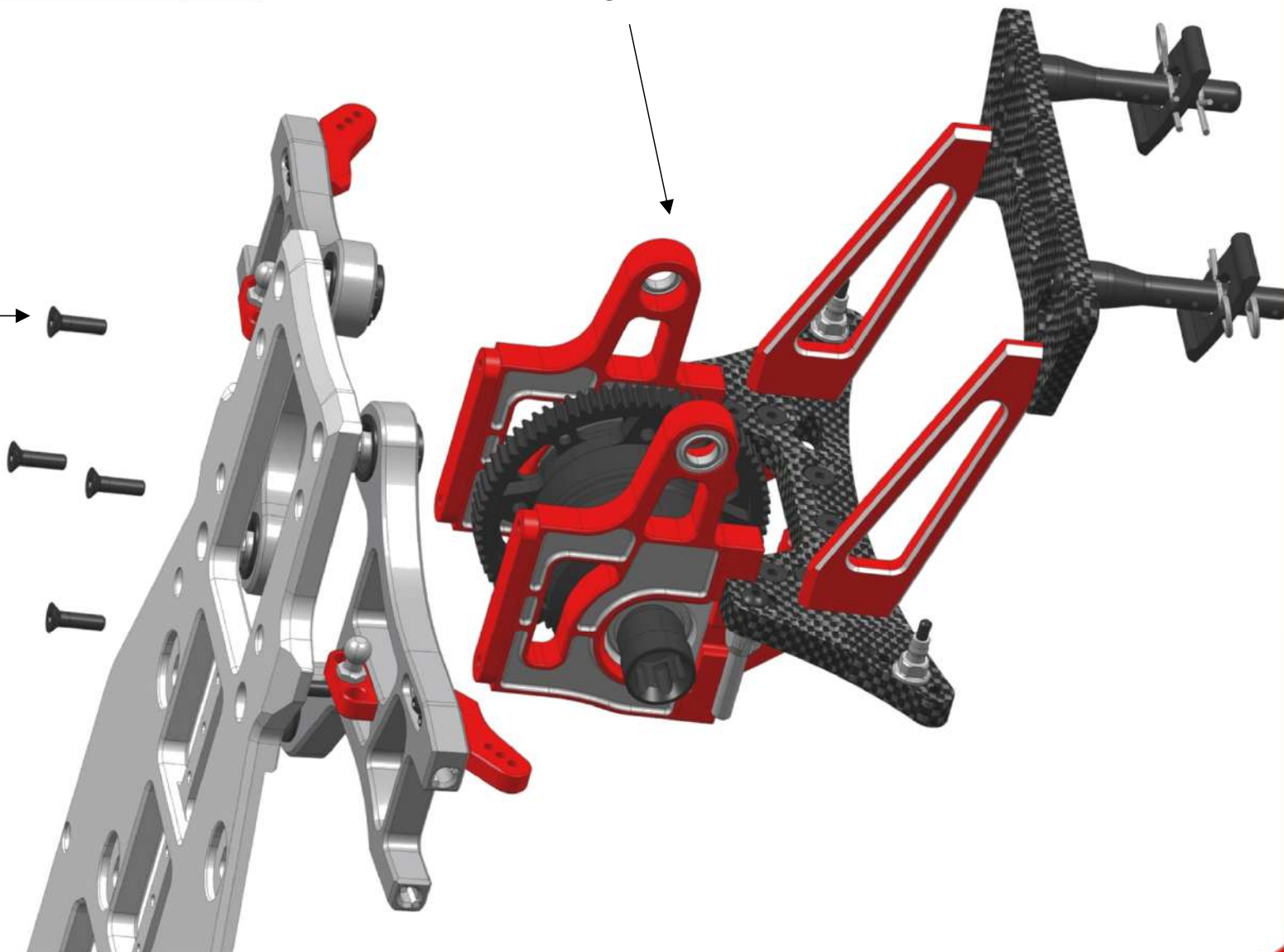

REAR UPPER SUSPENSION ARMS MOUNTING



#	Code	Part Name	Qty
1	Cap 4108	Rear Upper Suspension Arm Column Plate	1
2	Cap 2146	Countersunk Head Cap Screw M4x8	2
3	Cap 4126	Flange Nut Self-locking M5	2

(2x) REAR UPPER
SUSPENSION ARM

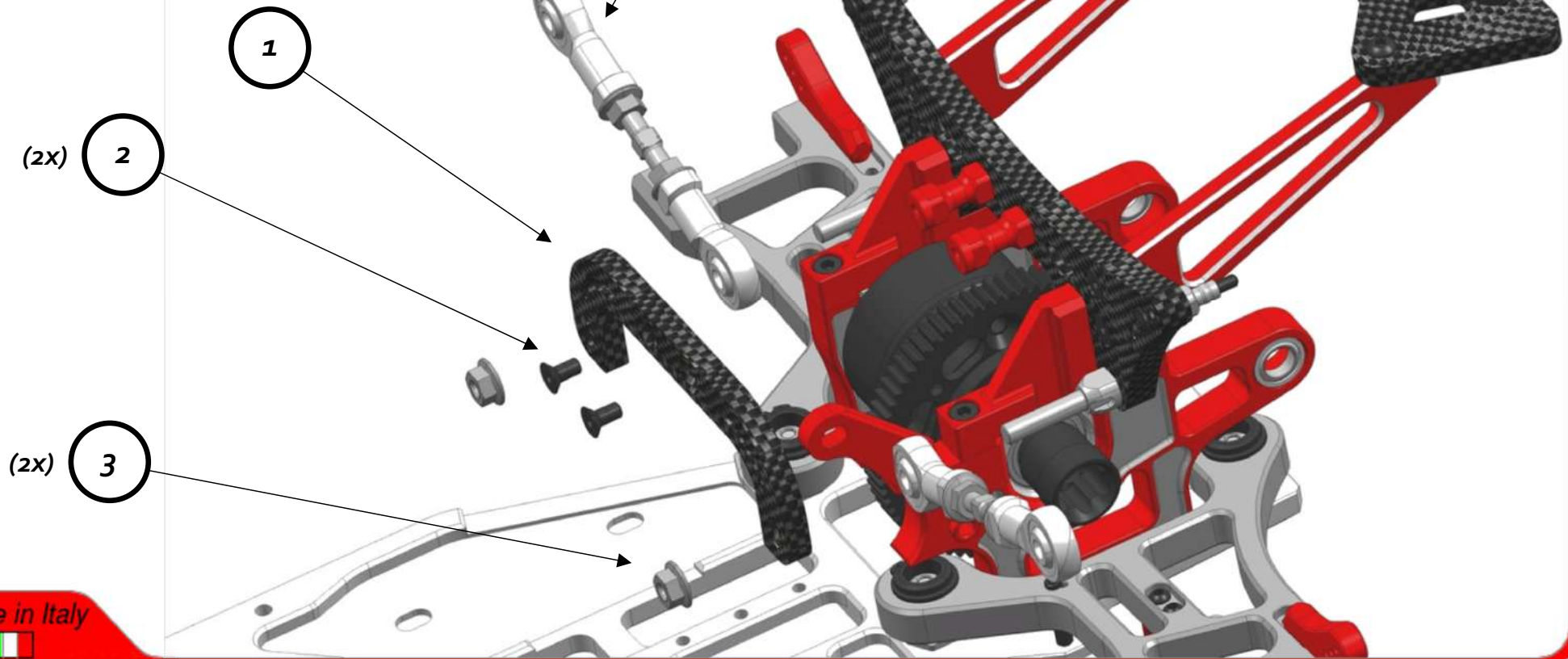



FRONT SWAY-BAR

#	Code	Part Name	Qty
1	Cap 4051	Sway-bar Shaft	1
2	Cap 4053	Sway-bar Shaft Spacer	1
3	Cap 4050	Sway-bar Holder	1
4	Cap 4052	Sway-bar Blade 1.7mm	1
5	Cap 17010	Grub Screw M4x4	1
6	Cap 4119	Grub Screw M5x5	1

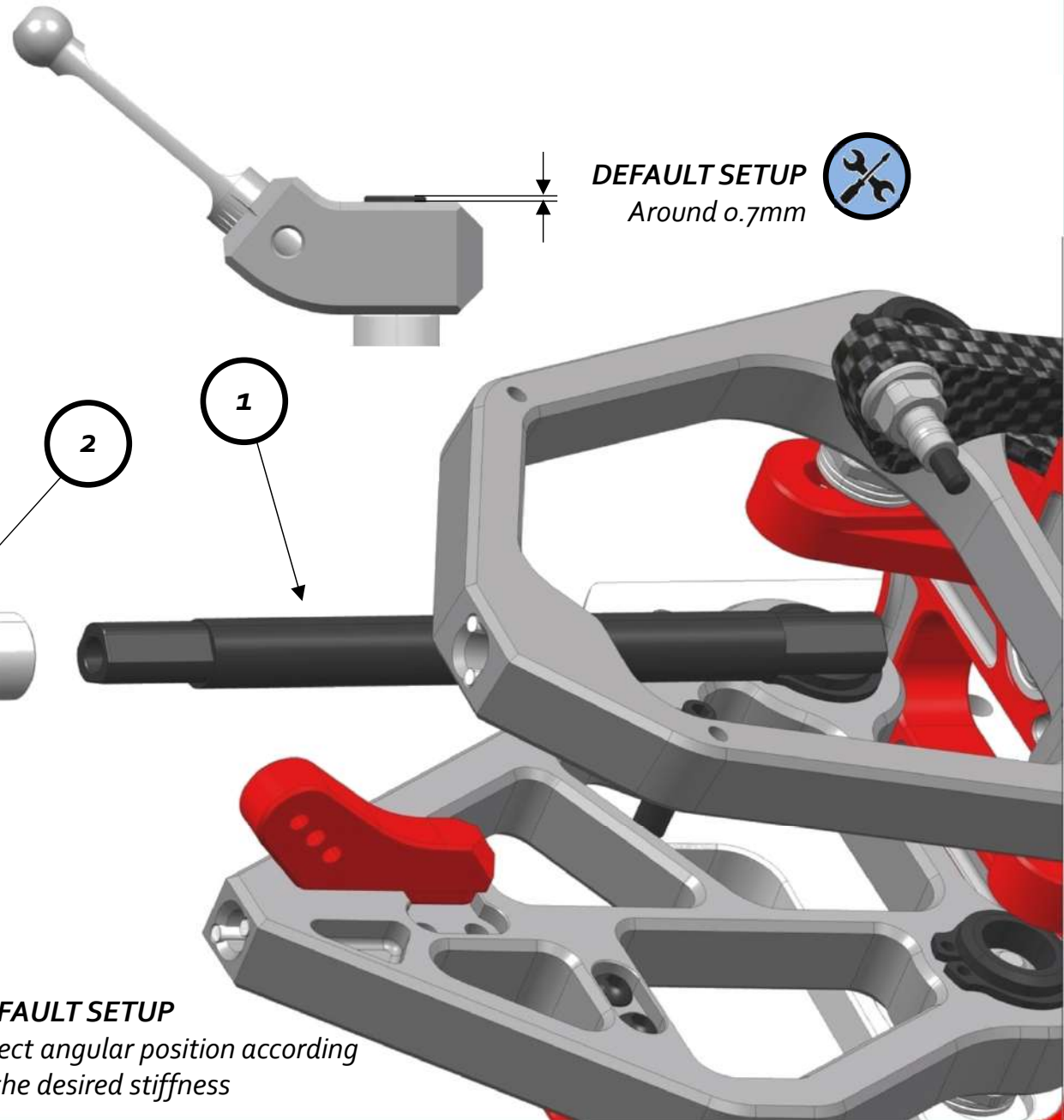



FRONT SWAY-BAR

#	Code	Part Name	Qty
1	Cap 4053	Sway-bar Shaft Spacer	1
2	Cap 4050	Sway-bar Holder	1
3	Cap 4052	Sway-bar Blade	1
4	Cap 17010	Grub Screw M4x4	1
5	Cap 4119	Grub Screw M5x5	1

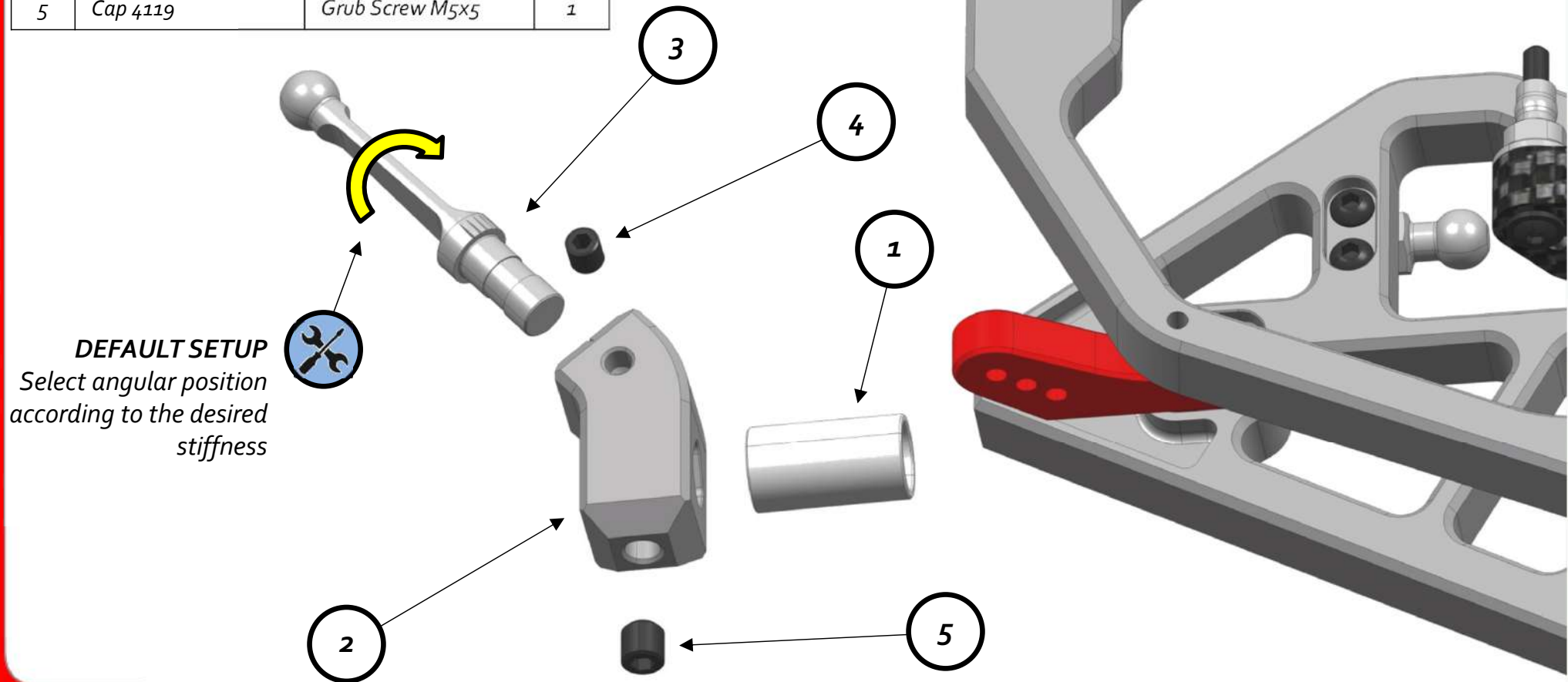

DEFAULT SETUP
 Select angular position
 according to the desired
 stiffness





REAR SWAY-BAR

#	Code	Part Name	Qty
1	Cap 4051	Sway-bar Shaft	1
2	Cap 4061	Sway-bar Holder Shim	2
3	Cap 4050	Sway-bar Holder	2
4	Cap 4052	Sway-bar Blade	2
5	Cap 17010	Grub Screw M4x4	2
6	Cap 4119	Grub Screw M5x5	2

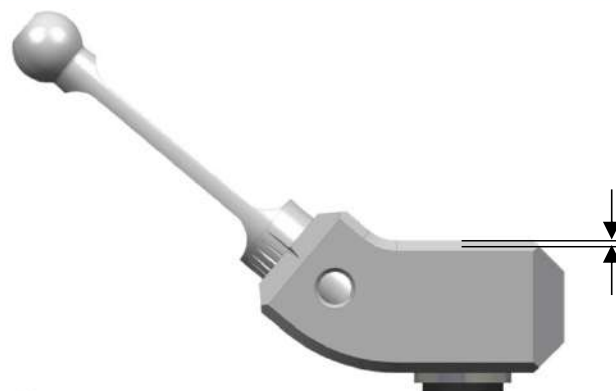

DEFAULT SETUP
The sway-bar holder must stick out around 0.2mm



DEFAULT SETUP
Select angular position according to the desired stiffness

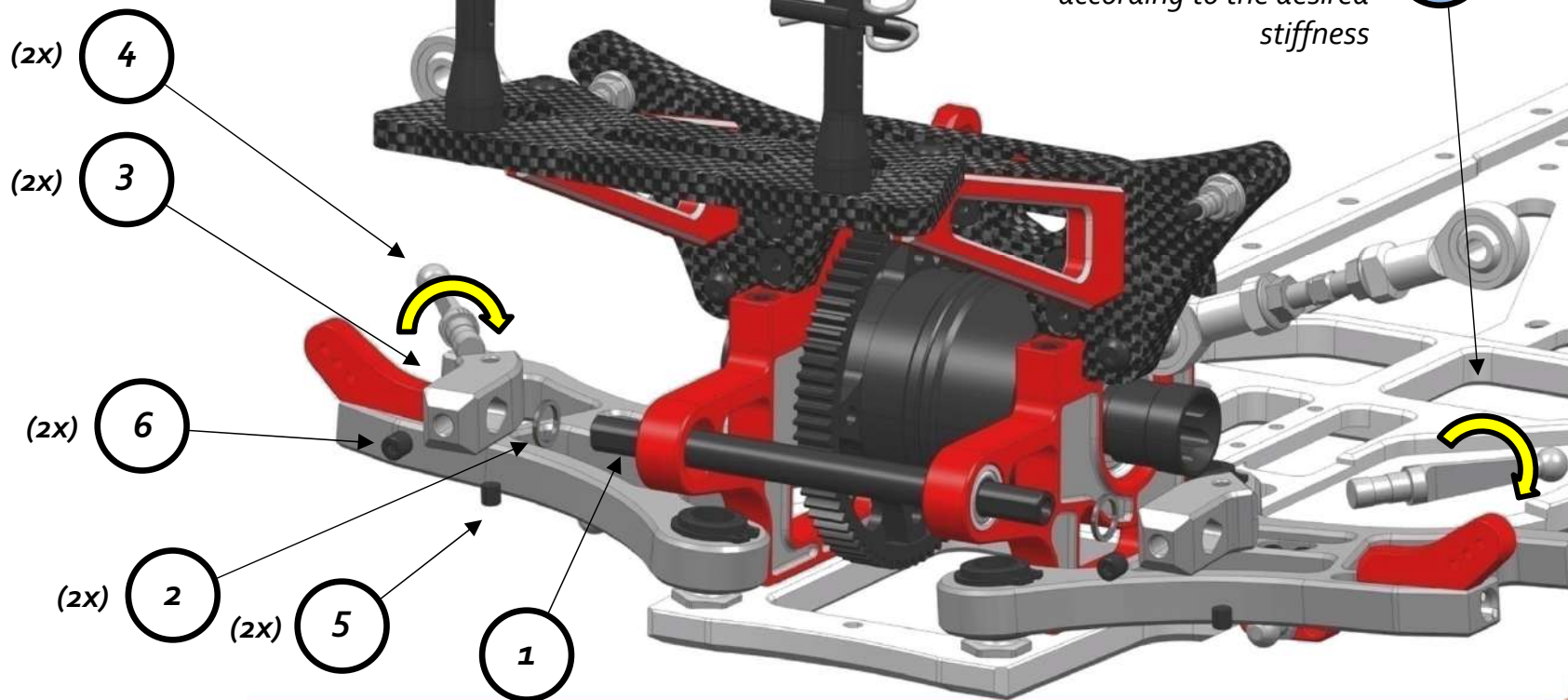

SWAY-BAR LINKS

#	Code	Part Name	Qty
1	Cap 2361	Uniball Link 7mm	8
2	Cap 4138	Turnbuckles M4x18	4

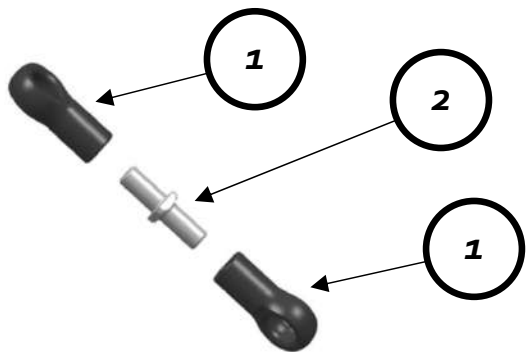
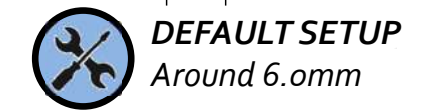
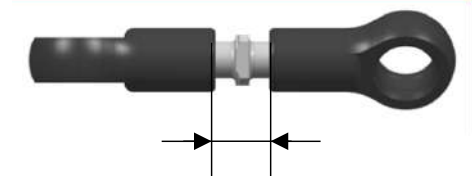

LEFT FRONT SWAY-BAR LINK

LEFT REAR SWAY-BAR LINK

RIGHT FRONT SWAY-BAR LINK

RIGHT REAR SWAY-BAR LINK

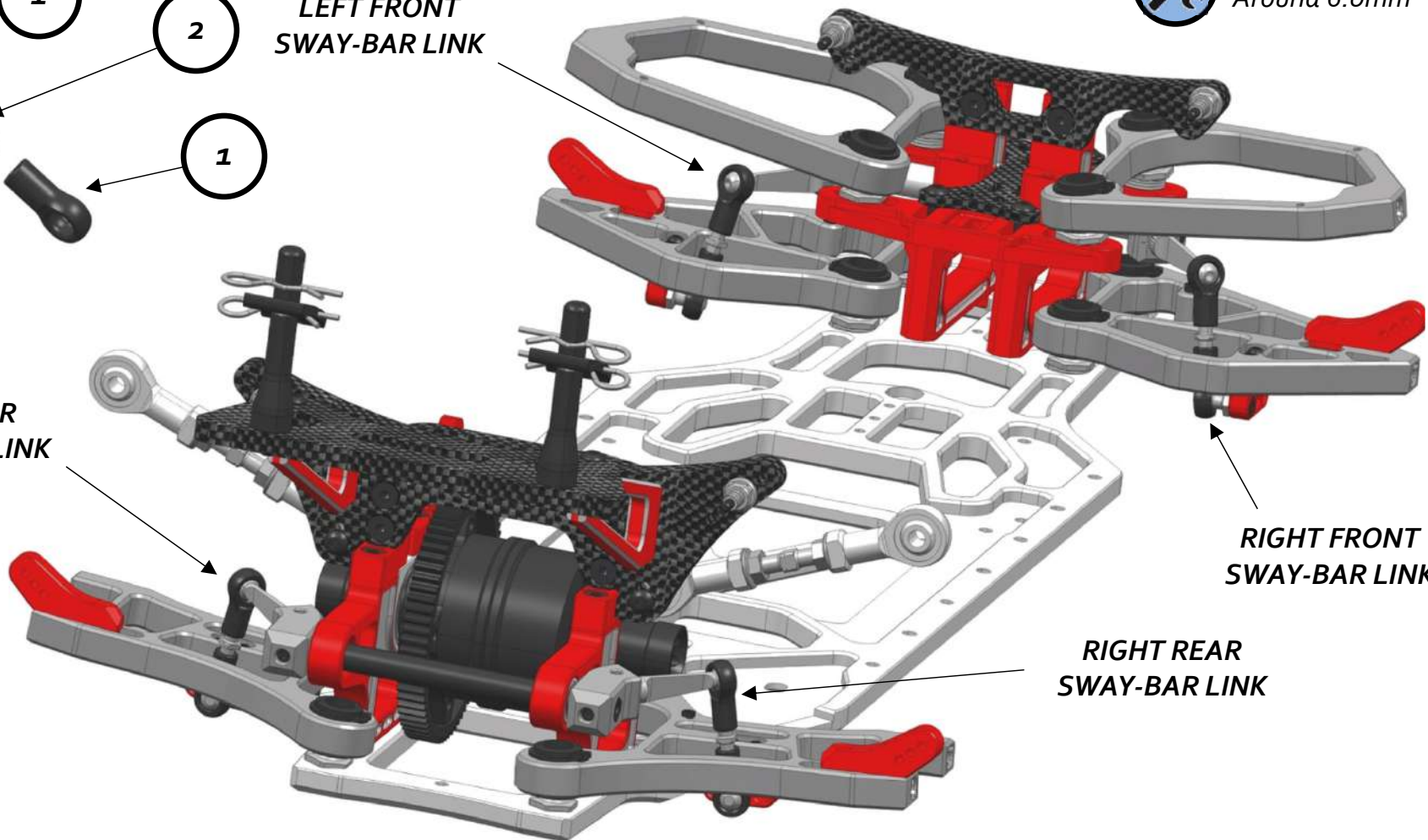



BUMPER MOUNTING

#	Code	Part Name	Qty
1	Cap 854	Flange Nut Self-locking M4	3
2	Cap 4117	Countersunk Head Cap Screw M4x14	3

BUMPER

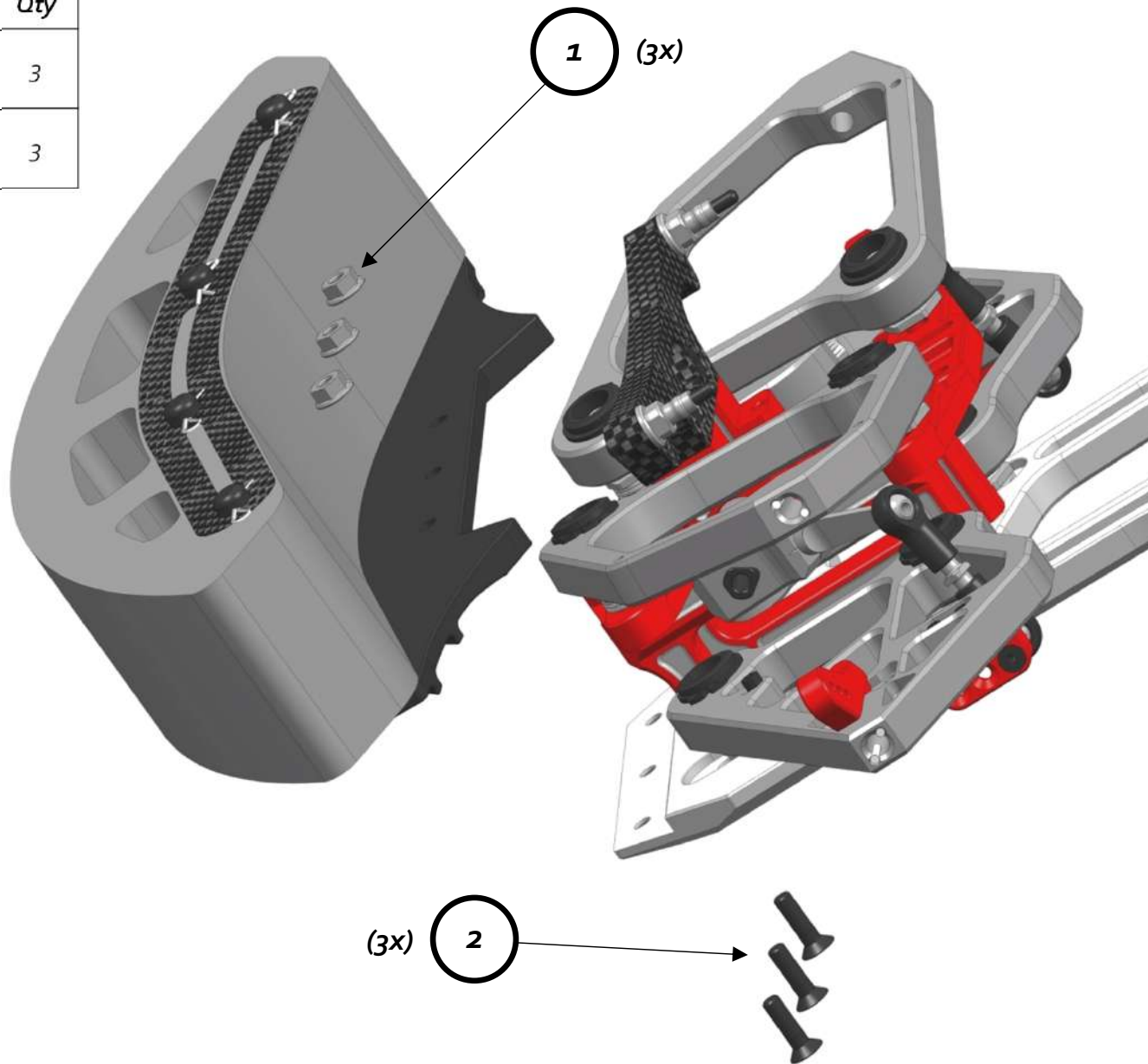

FRONT BODY HOLDER MOUNTING



#	Code	Part Name	Qty
1	Cap 4145	Button Head Cap Screw M ₄ x12	2

FRONT BODY HOLDER

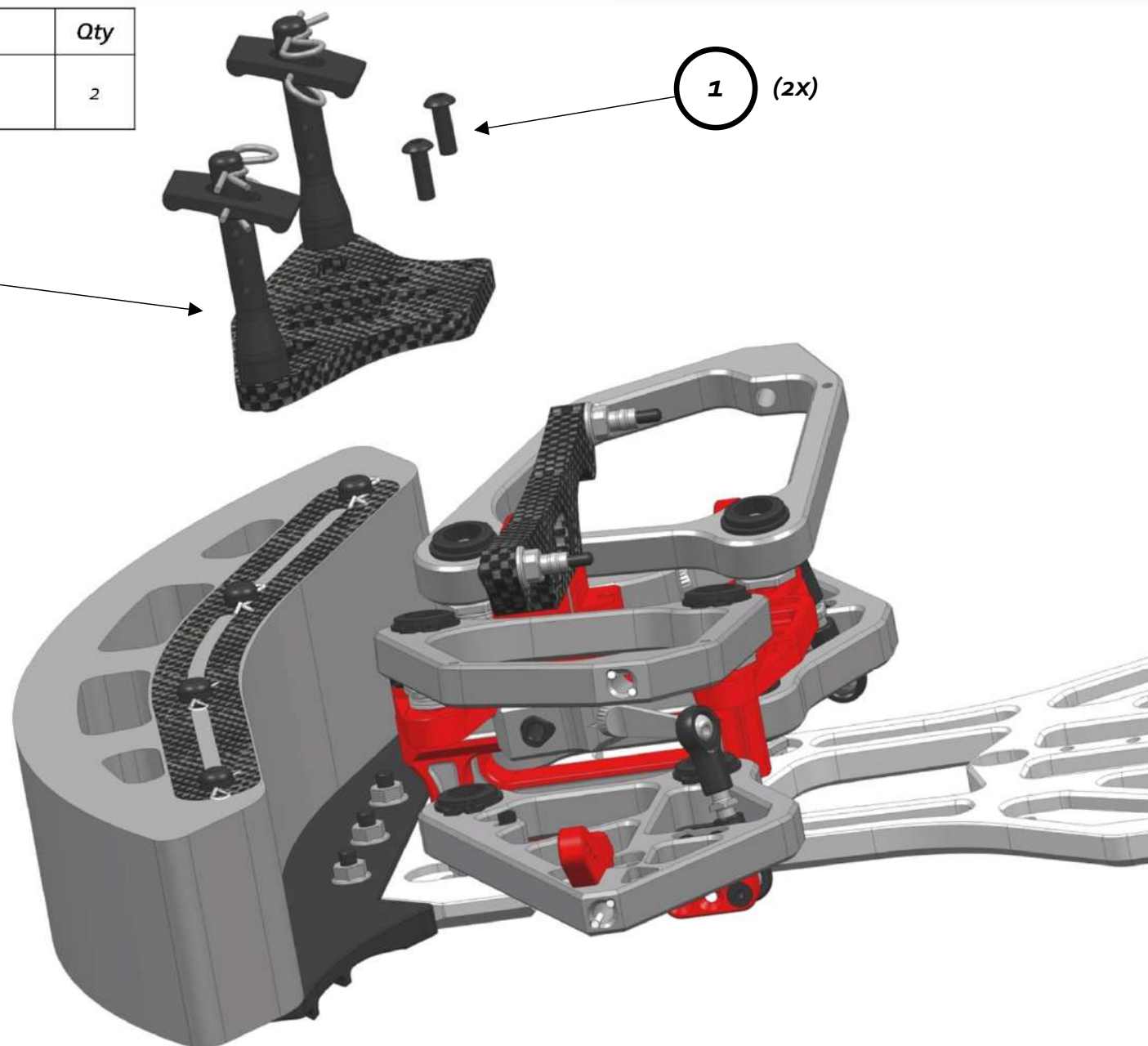



FRONT UPRIGHT

#	Code	Part Name	Qty
1	Cap 4021	Front Upright	2
2	Cap 4025	Bearing 8x19x6 6078 ZZ	4
3	Cap 4048	Front Upright Axle	2
4	Cap 4023	Front Upright Steering Extension	2
5	Cap 4023	Cylindrical Head Cap Screw M4x20	4
6	Cap 4095	Steering Stop	2
7	Cap 4121	Countersunk Head Cap Screw M4x25	2
8	Cap 4175	Upright Axle Spacer	2

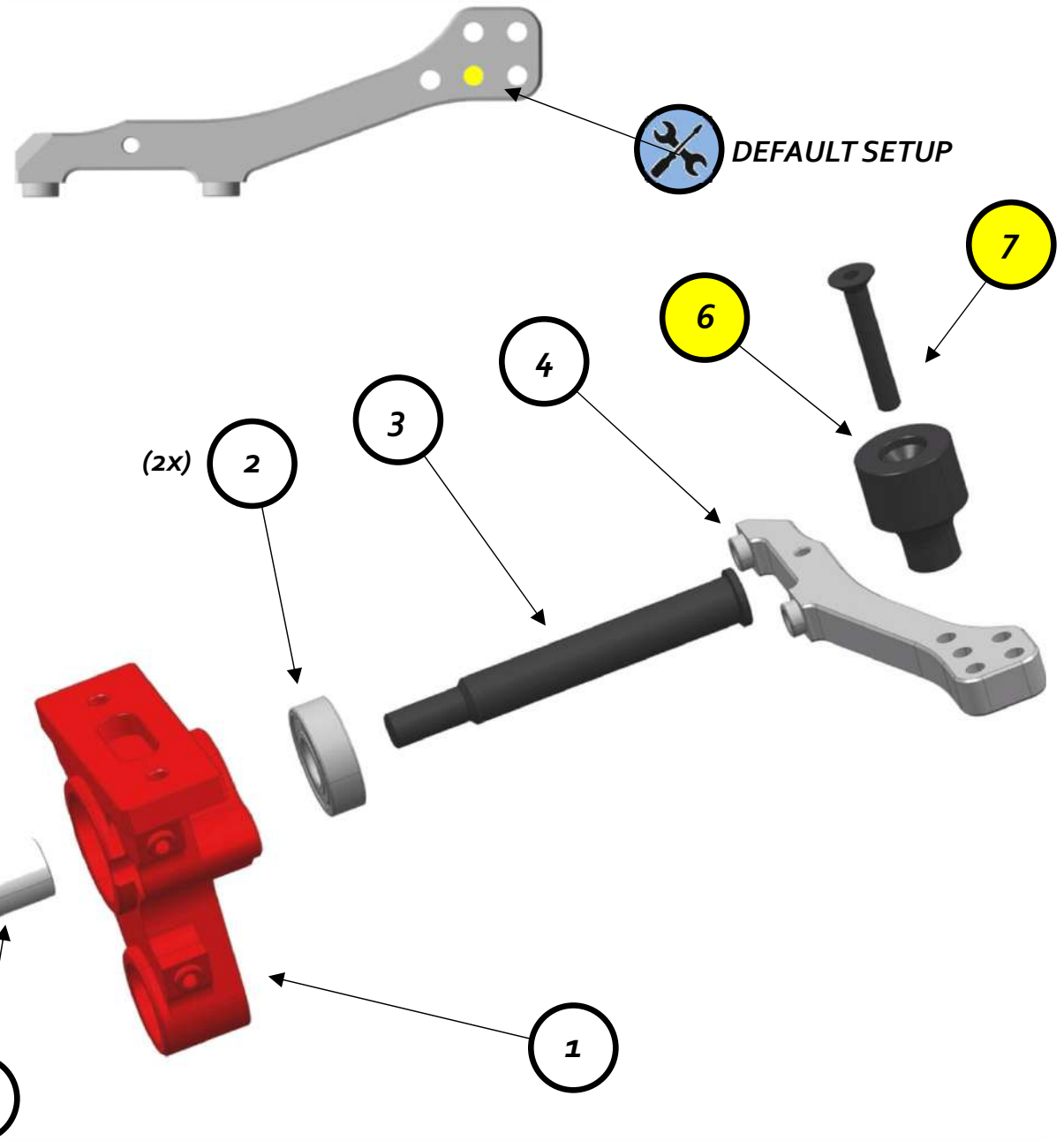



FRONT UPRIGHT

#	Code	Part Name	Qty
1	Cap 4046	Wheel Driver	2
2	Cap 4119	Grub Screw M5x5	4

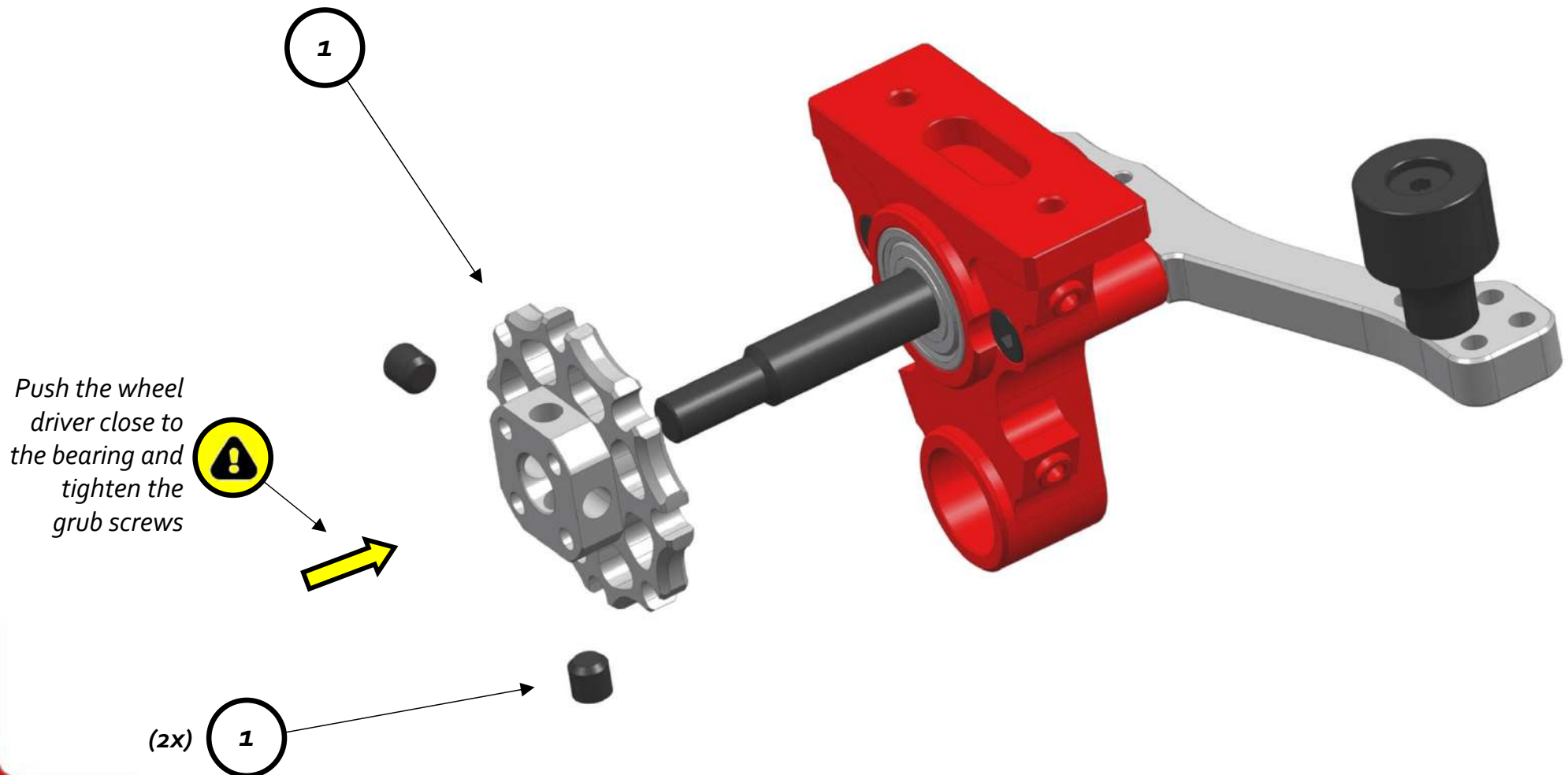



FRONT UPRIGHT

#	Code	Part Name	Qty
1	Cap 4022	Front Upper Upright	2
2	Cap 4035	Front Upper Upright Shim 1.0mm	2
3	Cap 4043	Upright Bushing A	4
4	Cap 4118	Countersunk Head Cap Screw M4x18	4
5	Cap 4101	Pivot Ball 13.8mm Long	2
6	Cap 4100	Pivot Ball 13.8mm	2
7	Cap 3044R-K	Adjusting Nut M15x1	4
8	Cap 3044R-K	OR 10x1.5	4

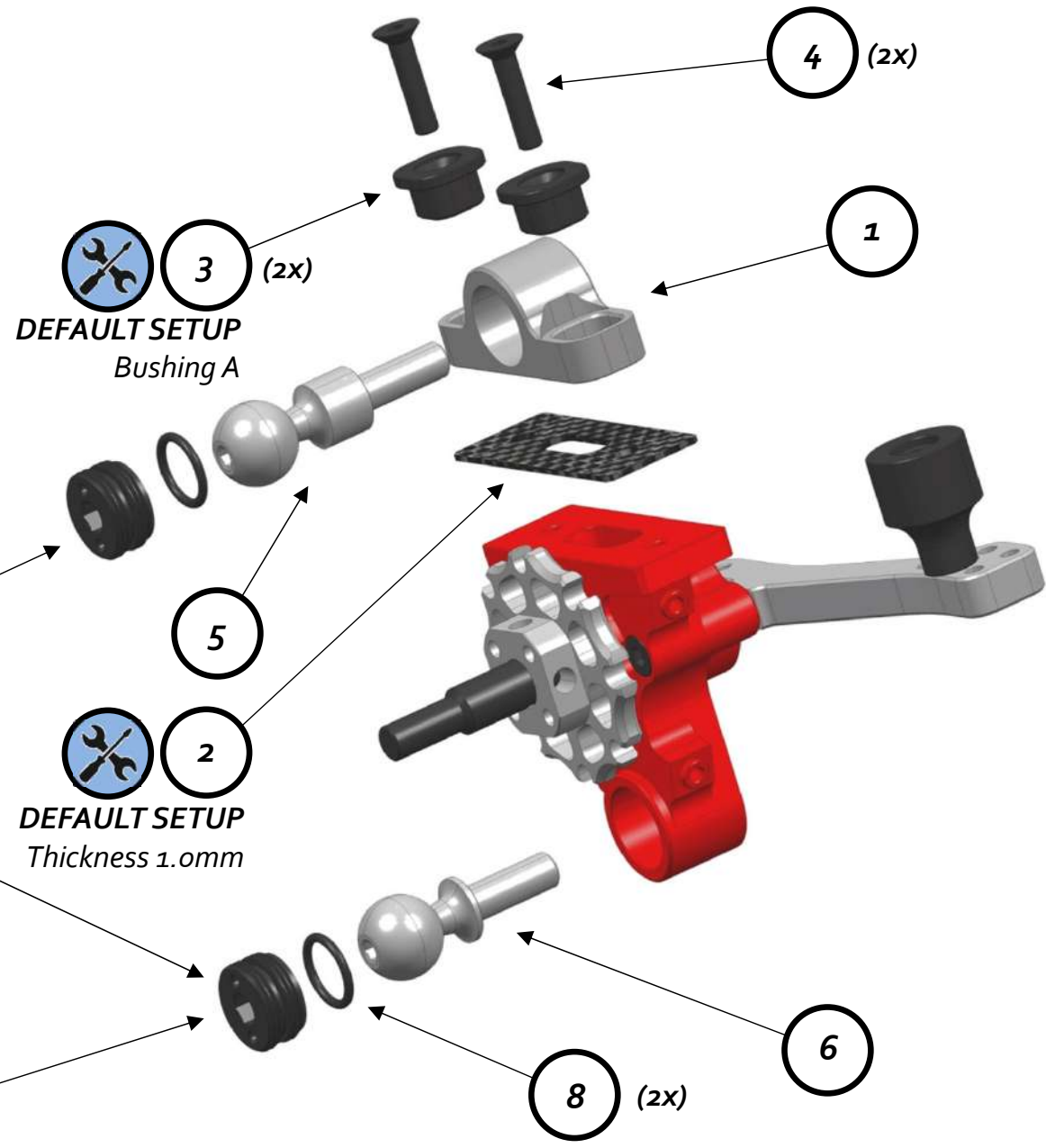

When tightening the nut
leave a little play
between the nut and
pivot ball so that the
pivot ball is free to move





FRONT UPRIGHT

BUILD **2X** L/R

#	Code	Part Name	Qty
1	Cap 4049	Brake Disc	2

1

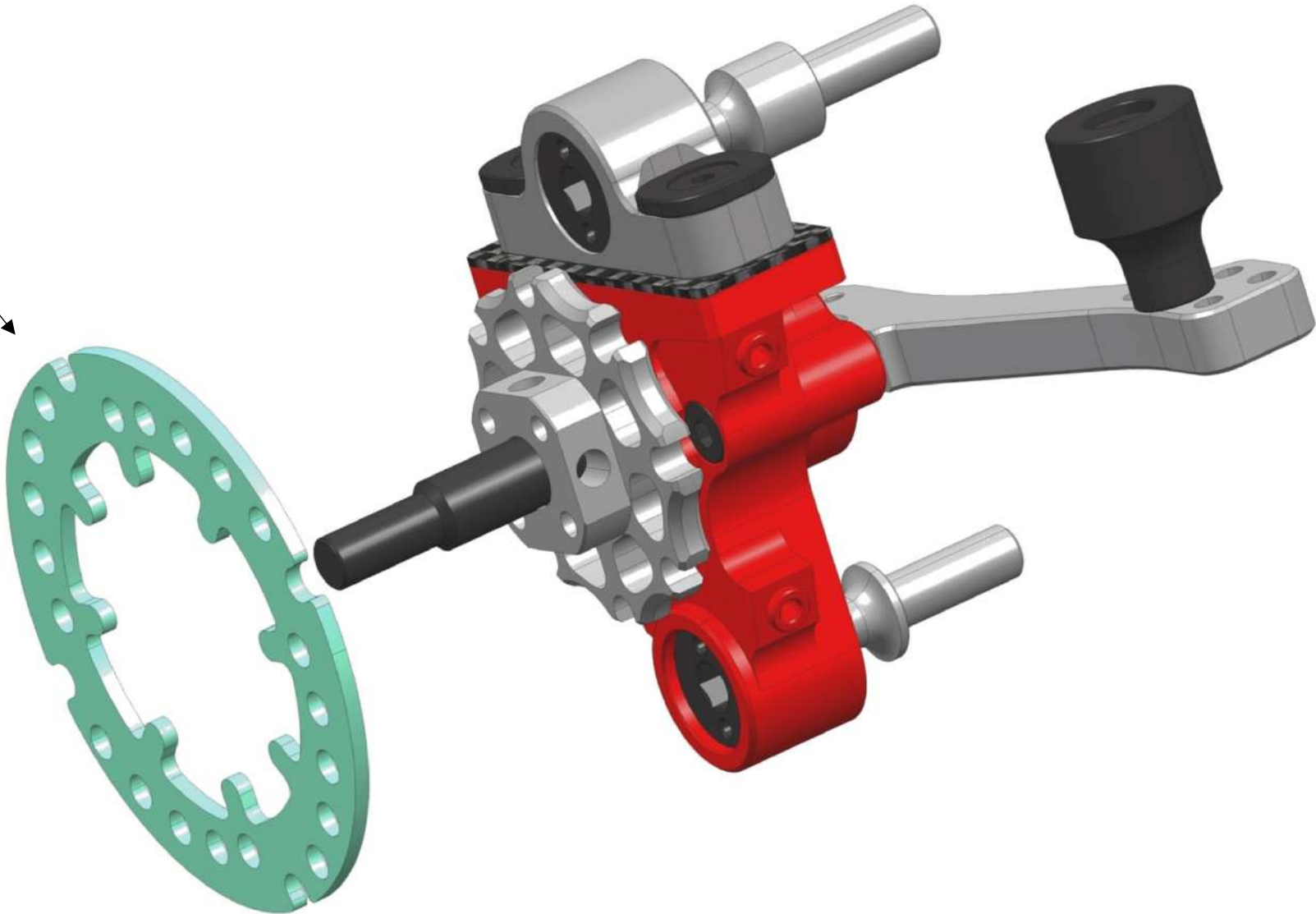



REAR UPRIGHT

#	Code	Part Name	Qty
1	Cap 4020	Rear Upright	2
2	Cap 4158	Rear Upright Upper Suspension Arm Extension Side 1	2
3	Cap 4159	Rear Upright Upper Suspension Arm Extension Side 2	2
4	Cap 2147	Button Head Cap Screw M4x8	8
5	Cap 4025	Bearing 8x19x6 6078 ZZ	4
6	Cap 4088	Rear Driving Axle	2
7	Cap 4175	Upright Axle Spacer	2

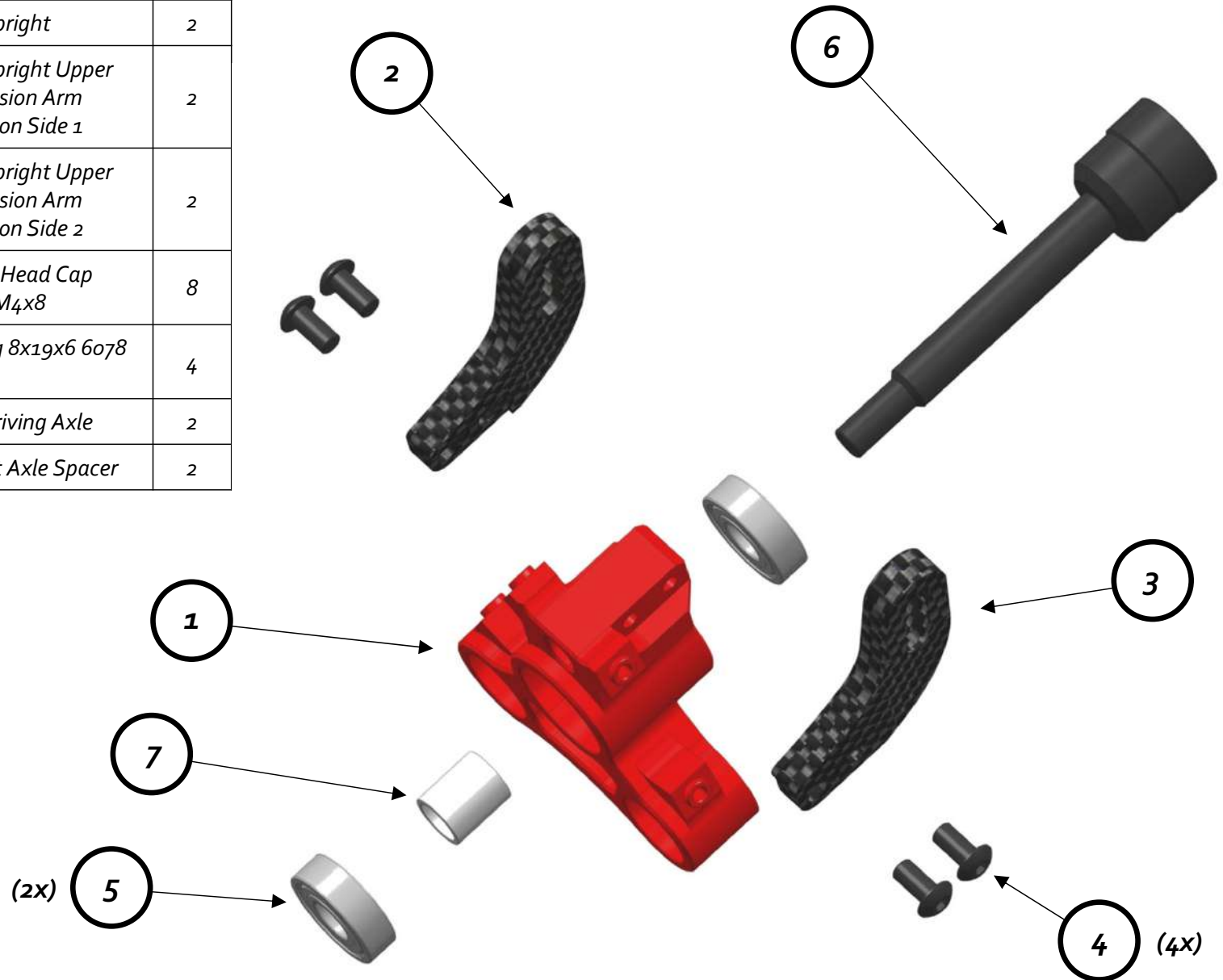



REAR UPRIGHT

#	Code	Part Name	Qty
1	Cap 4100	Pivot Ball 13.8mm	4
2	Cap 3044R-K	Adjusting Nut M15x1	4
3	Cap 3044R-K	OR 10x1.5	4

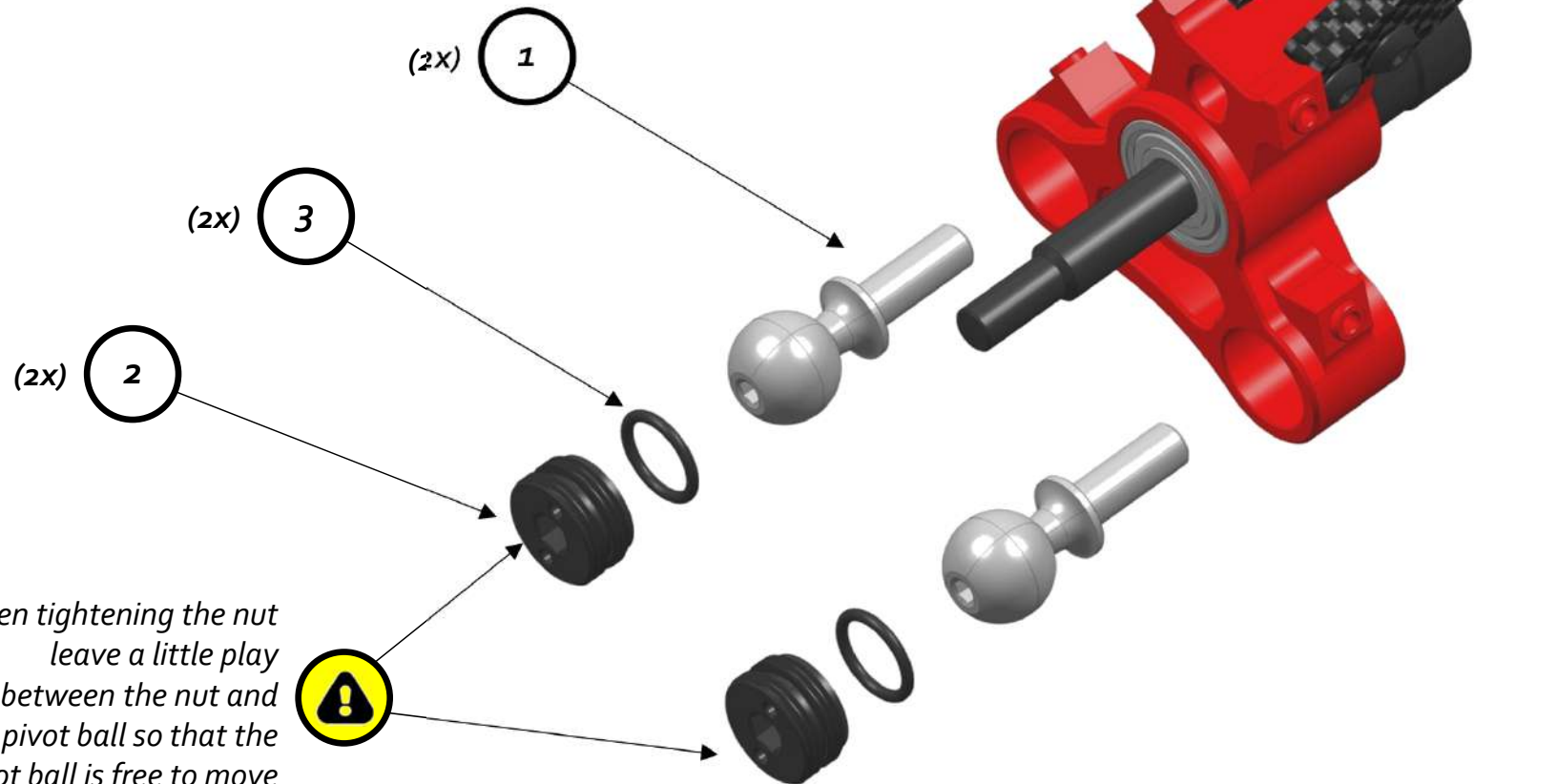

When tightening the nut
leave a little play
between the nut and
pivot ball so that the
pivot ball is free to move





#	Code	Part Name	Qty
1	Cap 4046	Wheel Driver	2
2	Cap 4119	Grub Screw M5x5	4

Push the wheel driver close to the bearing and tighten the grub screws

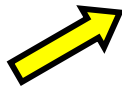
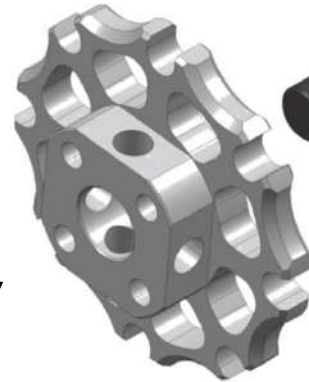
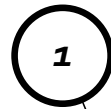

(2x)

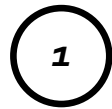



#	Code	Part Name	Qty
1	Cap 4049	Brake Disc	2

1

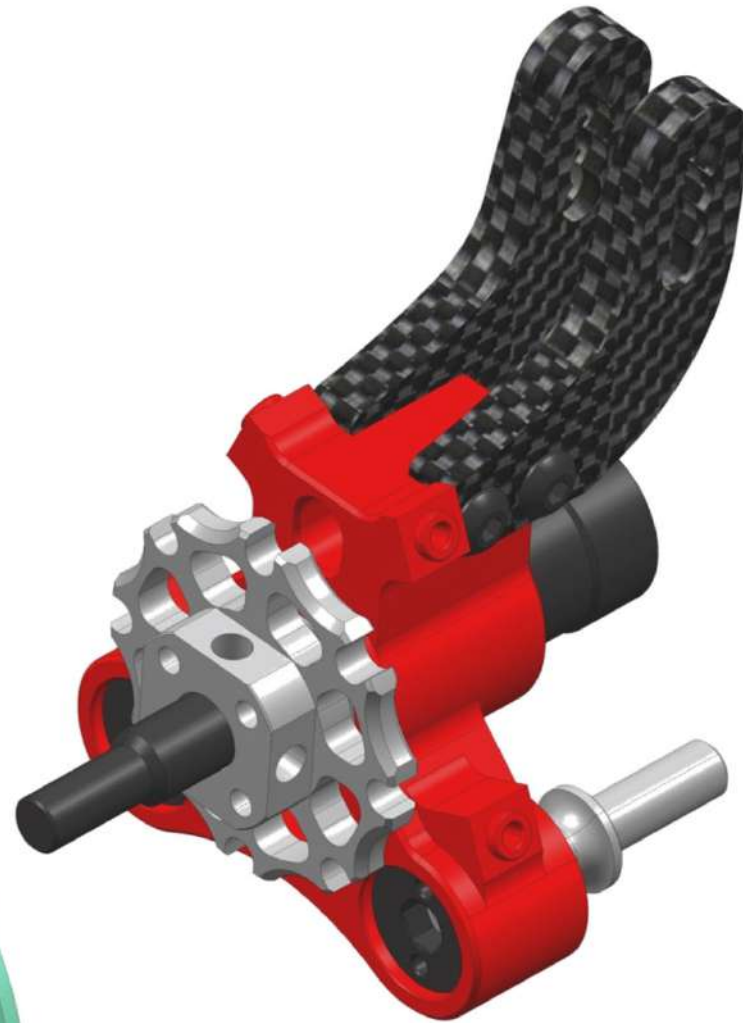
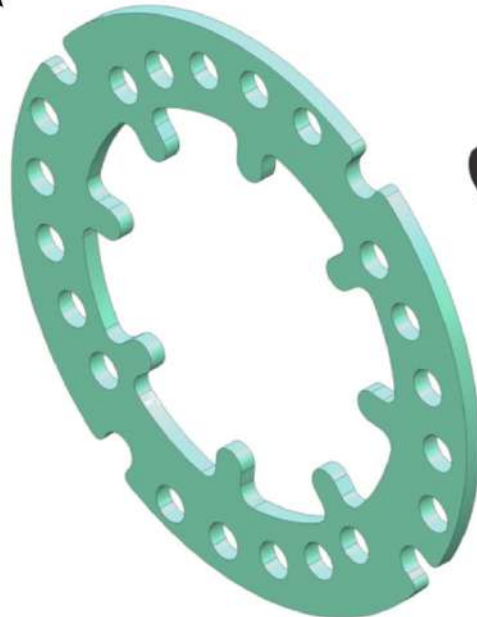

FRONT UPRIGHT MOUNTING



#	Code	Part Name	Qty
1	Cap 4062	Pivot Shim 1.0mm	14

FRONT UPRIGHT

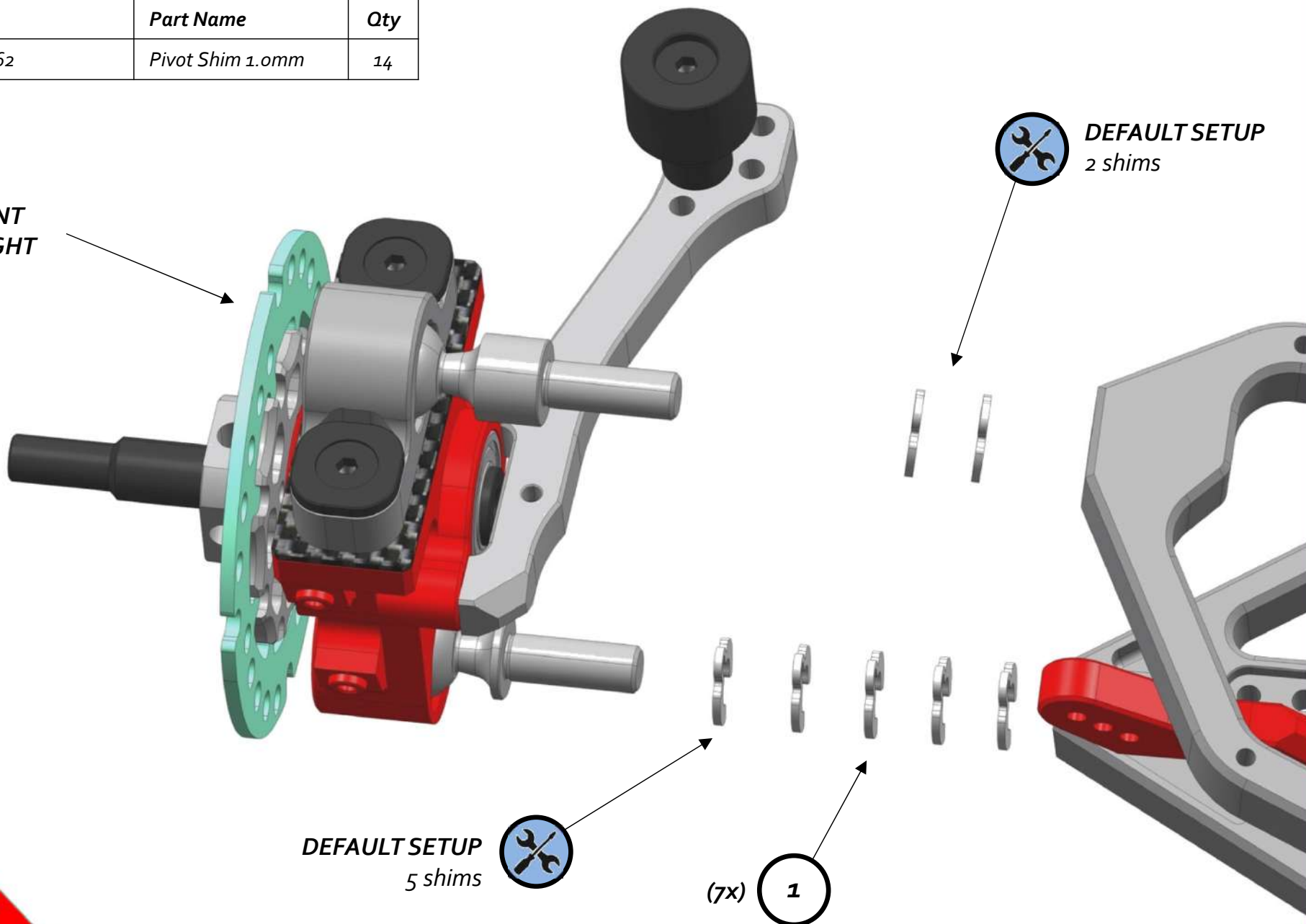

REAR UPRIGHT MOUNTING



#	Code	Part Name	Qty
1	Cap 4062	Pivot Shim 1.0mm	16
2	Cap 4093-K	Dogbone	2
3	Cap 4091	Protective Bellows	4
4	Cap 4131	Button Head Cap Screw M5x25	2
5	Cap 4126	Flange Nut Self-locking M5	2

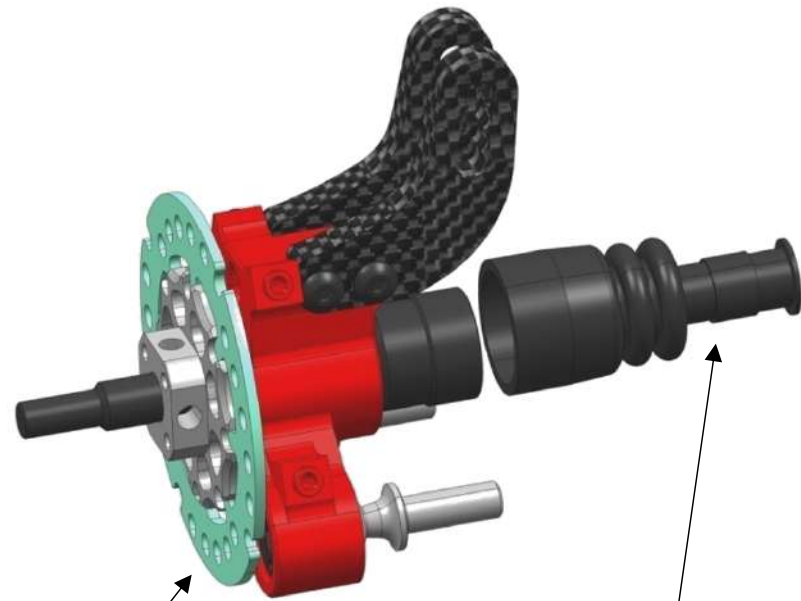

REAR UPRIGHT

(2x) 3

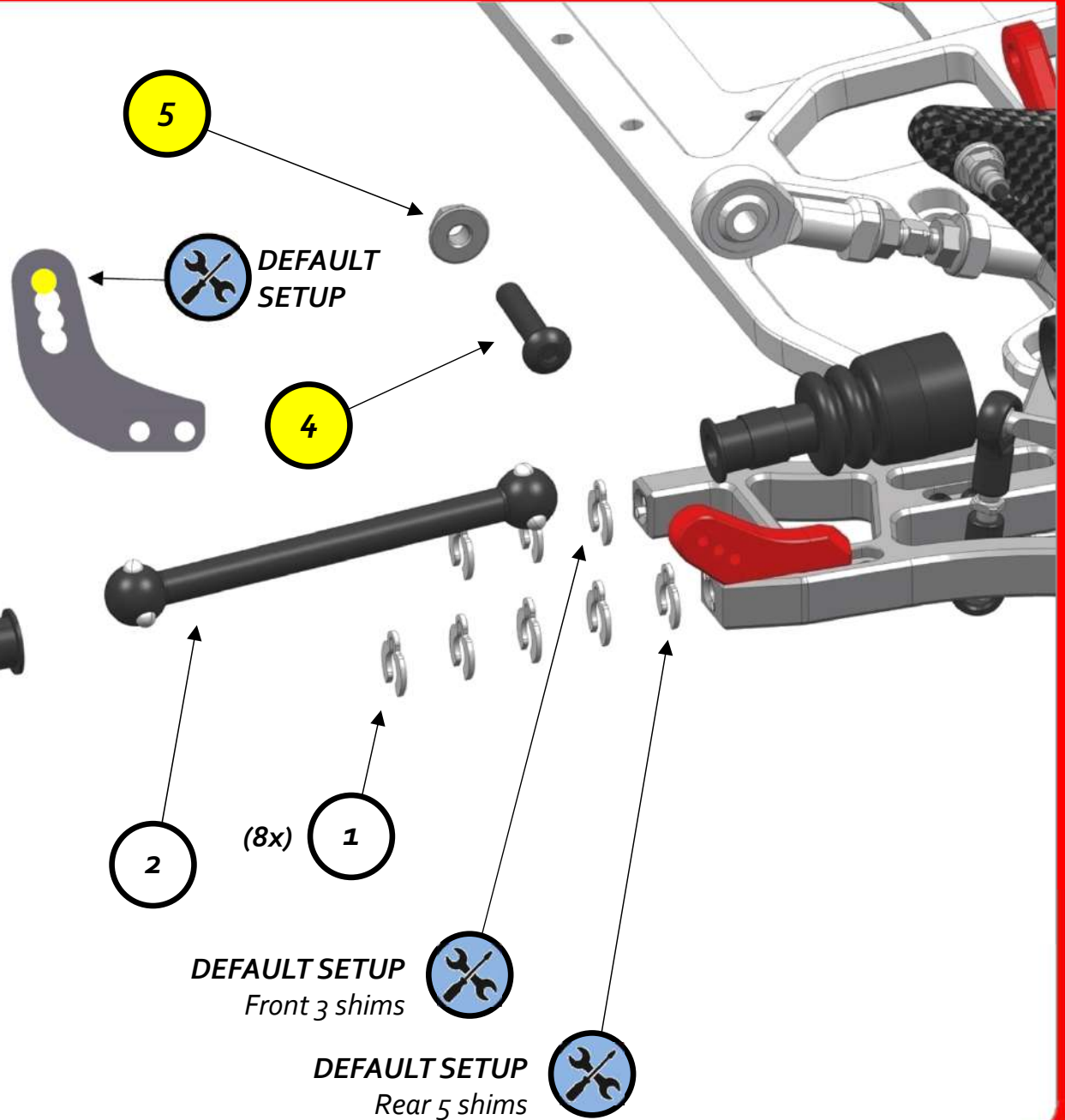

SERVO SAVER & STEERING LINK



#	Code	Part Name	Qty
1	Cap 4068	Servo Saver Column	1
2	Cap 4065	Servo Saver Cylinder	1
3	Cap 4029	Bearing 6x12x4 8706 ZZ	2
4	Cap 4063	Steering Bellcrank	1
5	Cap 4067	Steering Bellcrank Upper	1
6	Cap 4072	Shim 18x22x0.2	2
7	Cap 4069	Servo Saver Spring	1
8	Cap 4066	Servo Saver Spring Ring	1
9	Cap 4073	OR 16x1.78	1



DEFAULT SETUP
Around 13.4mm

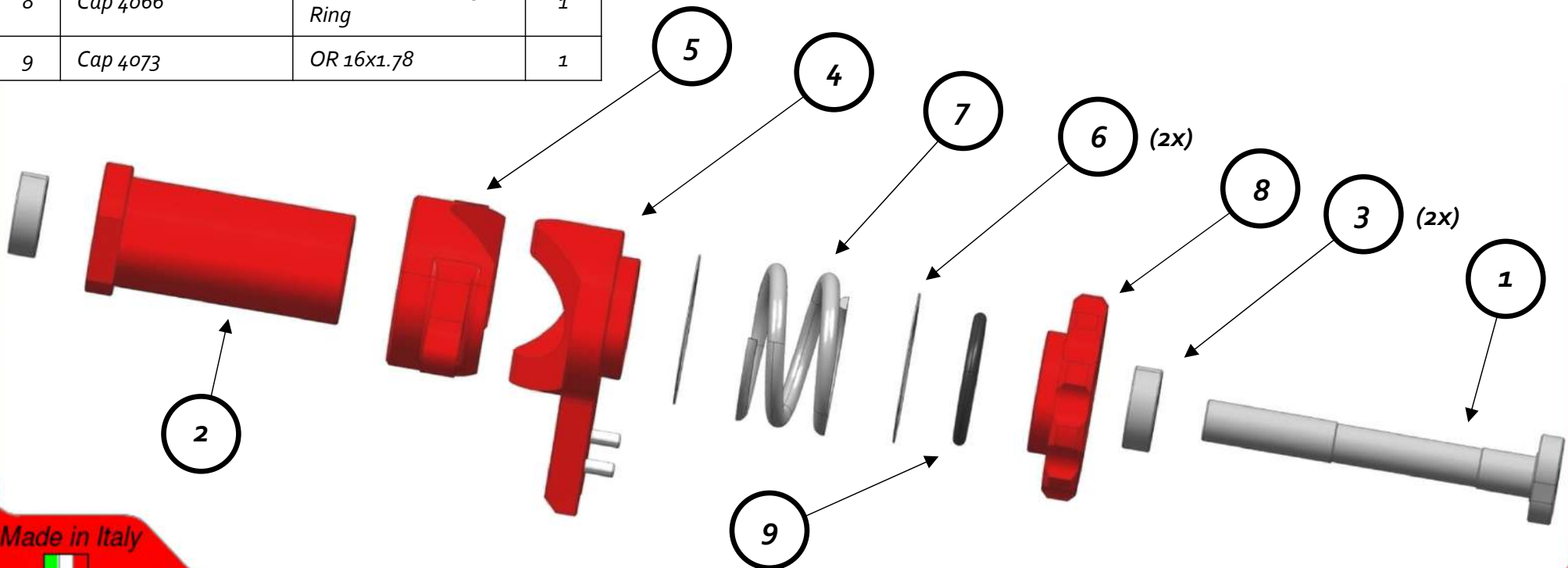
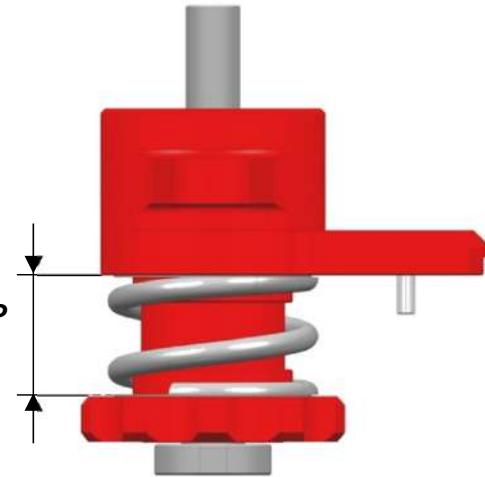

SERVO SAVER & STEERING LINK



#	Code	Part Name	Qty
1	Cap 4070	Servo Saver Pivotball 7.0mm	2
2	Cap 4166	Countersunk Head Cap Screw M4x10	2
3	Cap 4059	Servo Saver Stiffener Spacer Shim	1

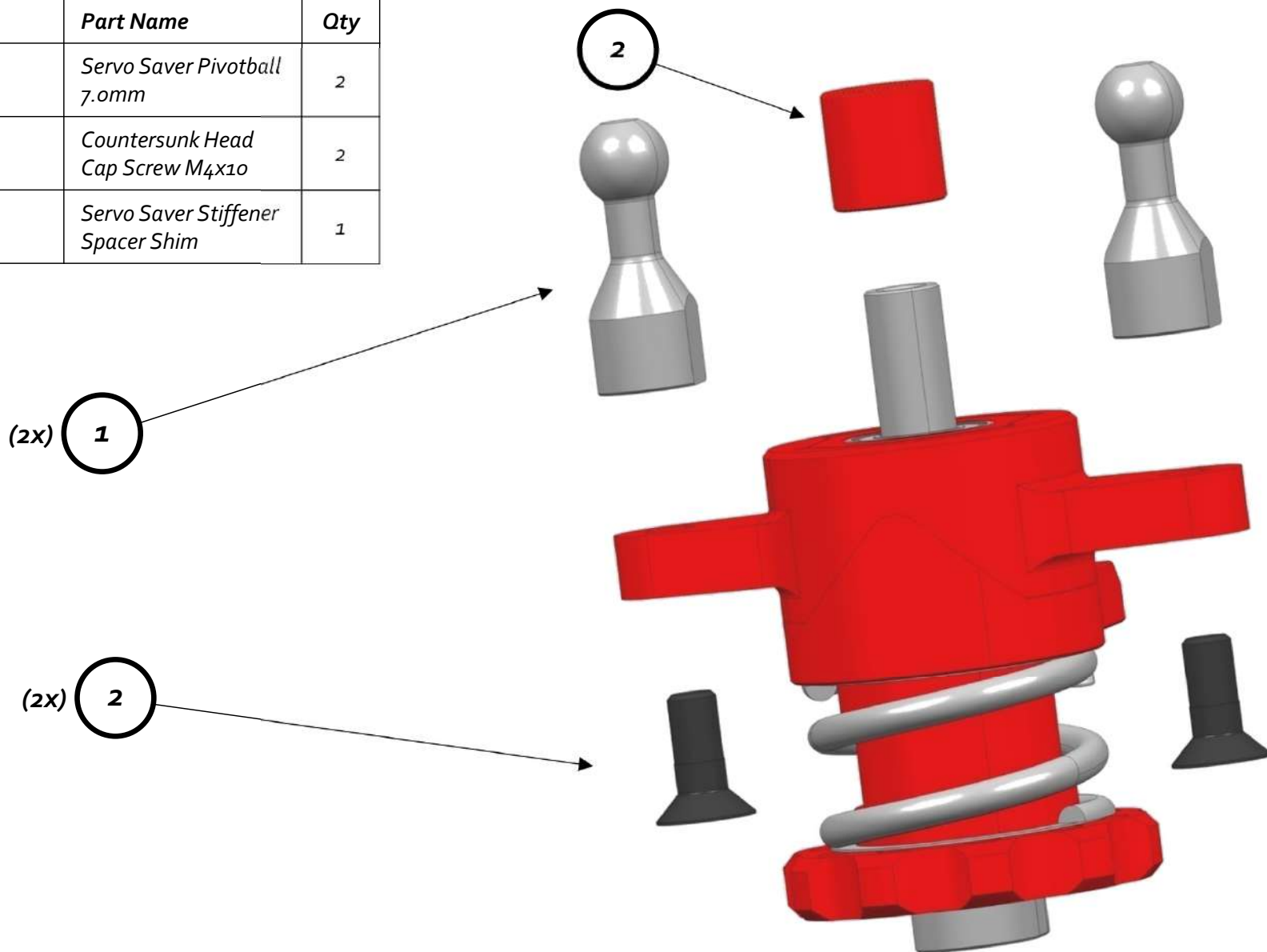

**SERVO SAVER &
STEERING LINK**



#	Code	Part Name	Qty
1	Cap 3041	Turnbuckle M4x84	2
2	Cap 2361	Uniball Link 7mm	2
3	Cap 3179	Uniball Link 7mm Long	2

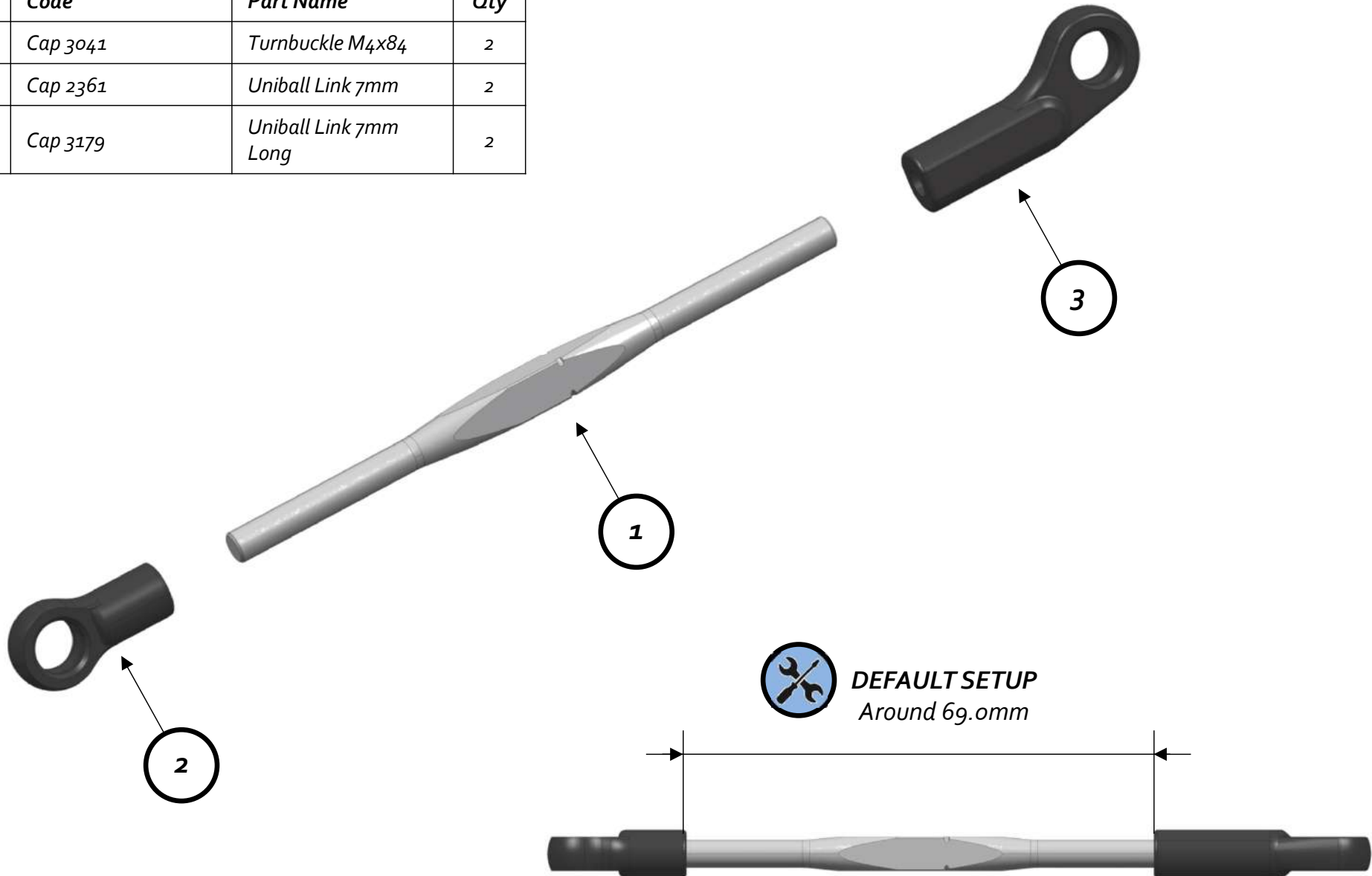

SERVO SAVER & STEERING LINK



#	Code	Part Name	Qty
1	Cap 4064	Steering Bellcrank Extension	1
2	Cap 4141	Washer M5	1
3	Cap 4142	Button Head Cap Screw M5X10	1
4	Cap 4071	Steering Pivotball 7.0mm	2
5	Cap 4156	Button Head Cap Screw M4x16	2

DEFAULT SETUP

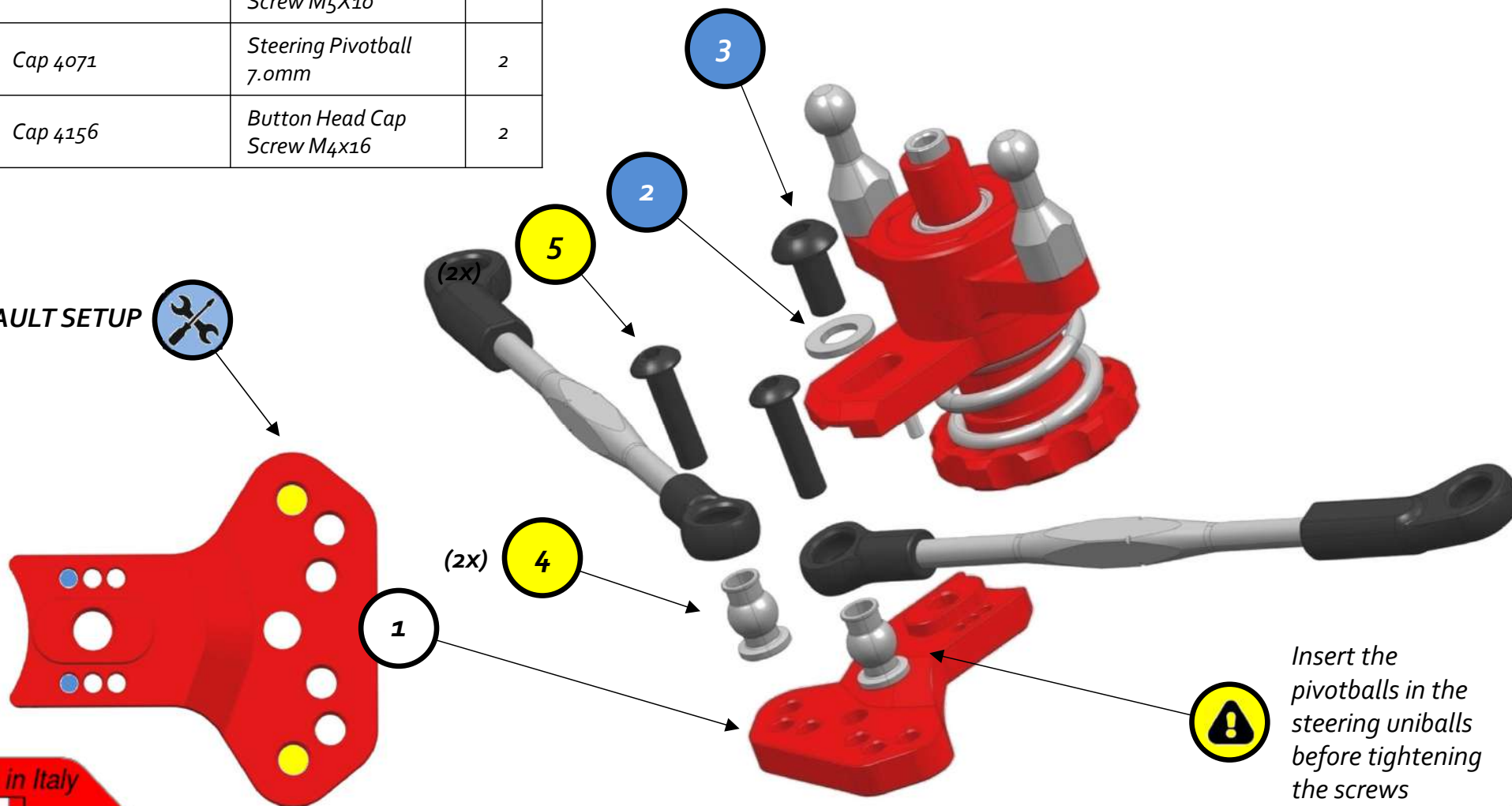

Insert the pivotballs in the steering uniballs before tightening the screws



STEERING SERVO & LINKS MOUNTING



#	Code	Part Name	Qty
1	Cap 2145	Countersunk Head Cap Screw M4x12	1
2	Cap 4071	Steering Pivotball 7.0mm	2
3	Cap 4174	Button Head Cap Screw M4x20	2

SERVO SAVER & STEERING LINK

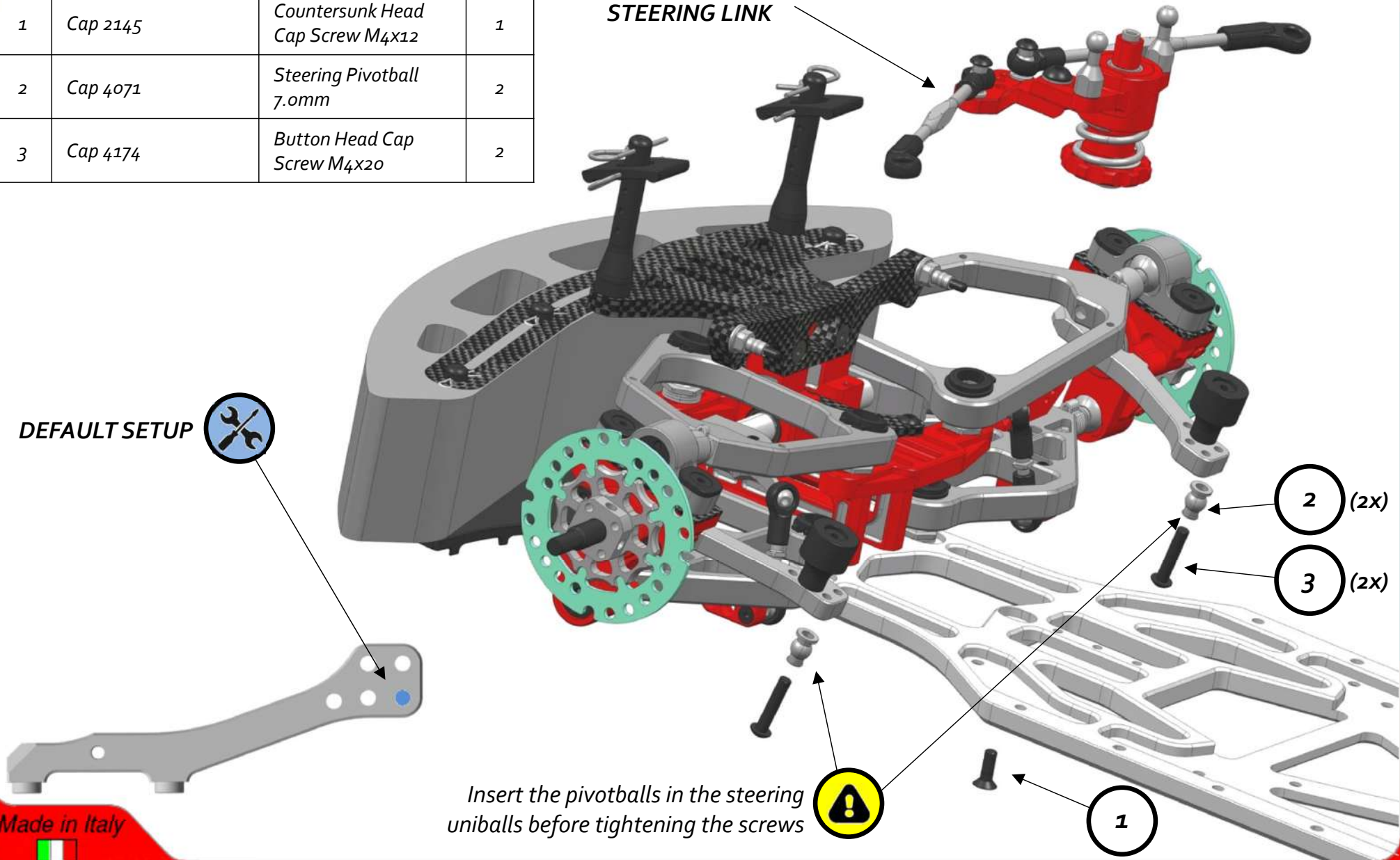



TANK MOUNTING

#	Code	Part Name	Qty
1	Cap 4148	Tank	1
2	Cap 2145	Countersunk Head Cap Screw M4x12	3

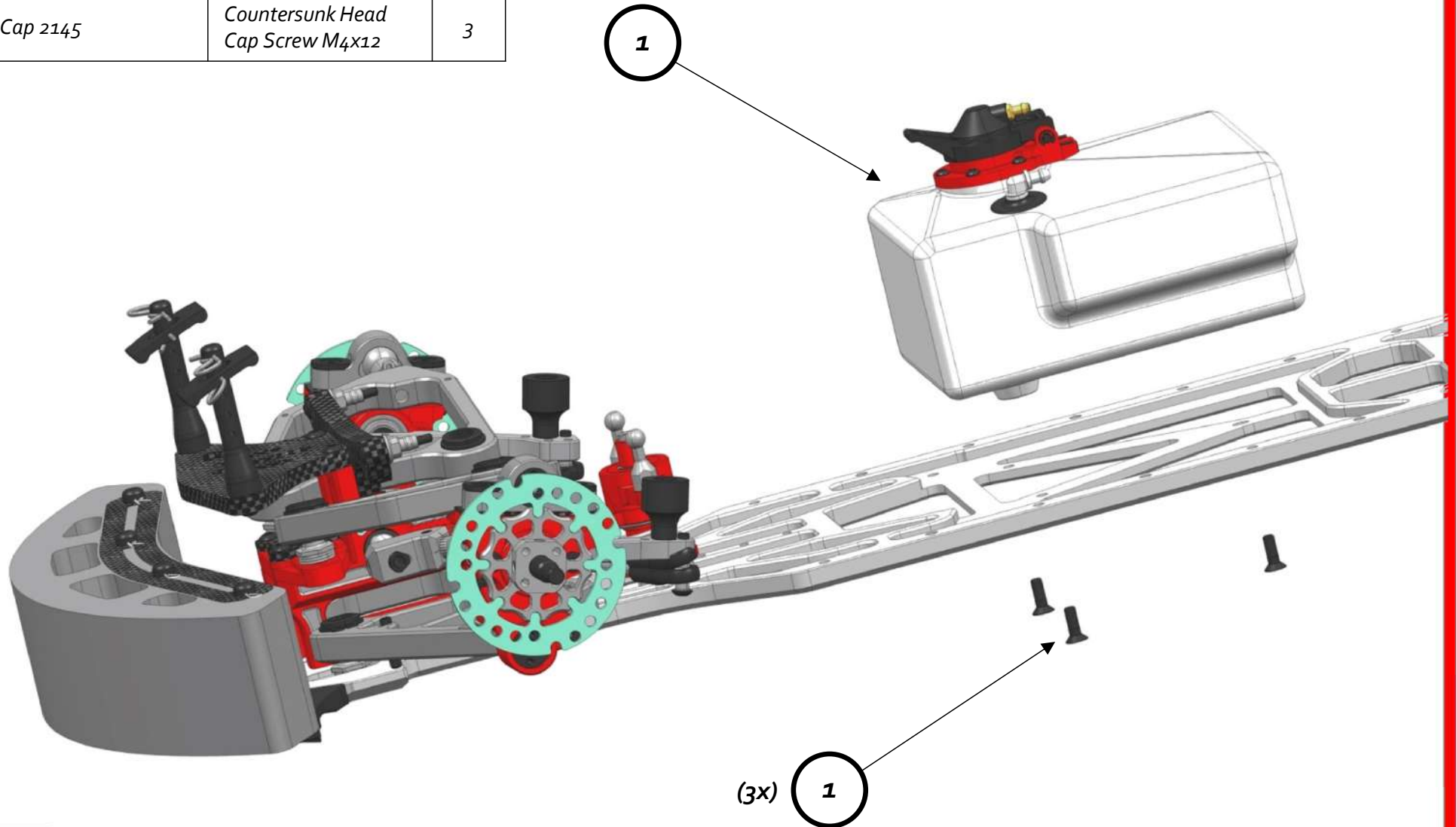

LATERAL RIGHT STIFFENER



#	Code	Part Name	Qty
1	Cap 4004	Lateral Stiffener	1
2	Cap 4042	Lateral Protection	1
3	Cap 27002	Clip	2
4	Cap 4139	Lateral Body Holder Column	2
5	Cap 4113	Countersunk Head Cap Screw M4x16	2
6	Cap 4076	Lateral Engine Fixation	1
7	Cap 4077	Lateral Engine Fixation Bushing	1
8	Cap 4132	Cylindrical Head Cap Screw M5x16	2
9	Cap 4167	Cylindrical Head Cap Screw M4x25	1

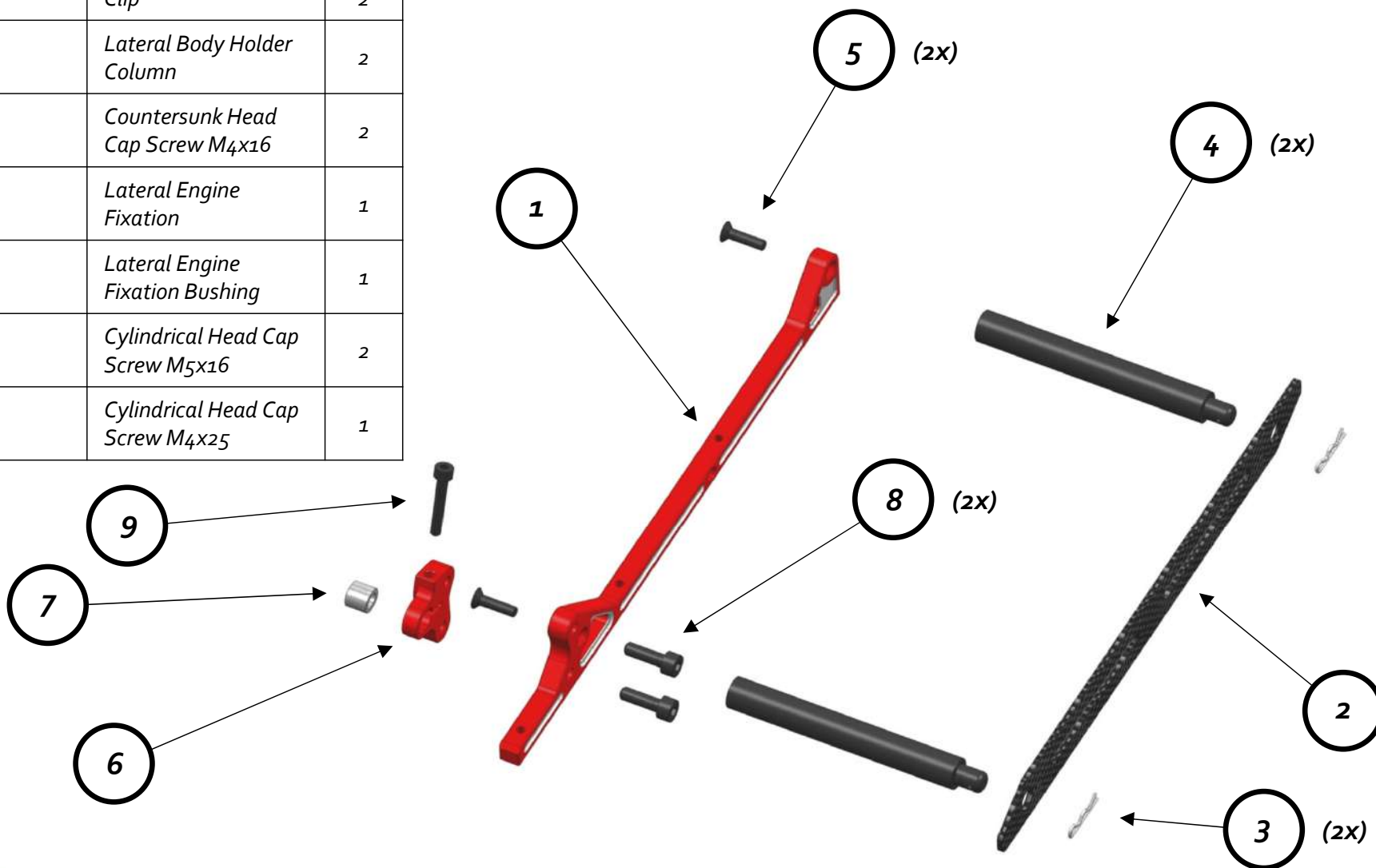

BATTERY HOLDER



#	Code	Part Name	Qty
1	Cap 4040	Battery Holder Plate	1
2	Cap 4075	Battery Holder Box	1
3	Cap 4084	Carbon Fiber Nut M3	8
4	Cap 17027	Countersunk Head Cap Screw M3x10	8

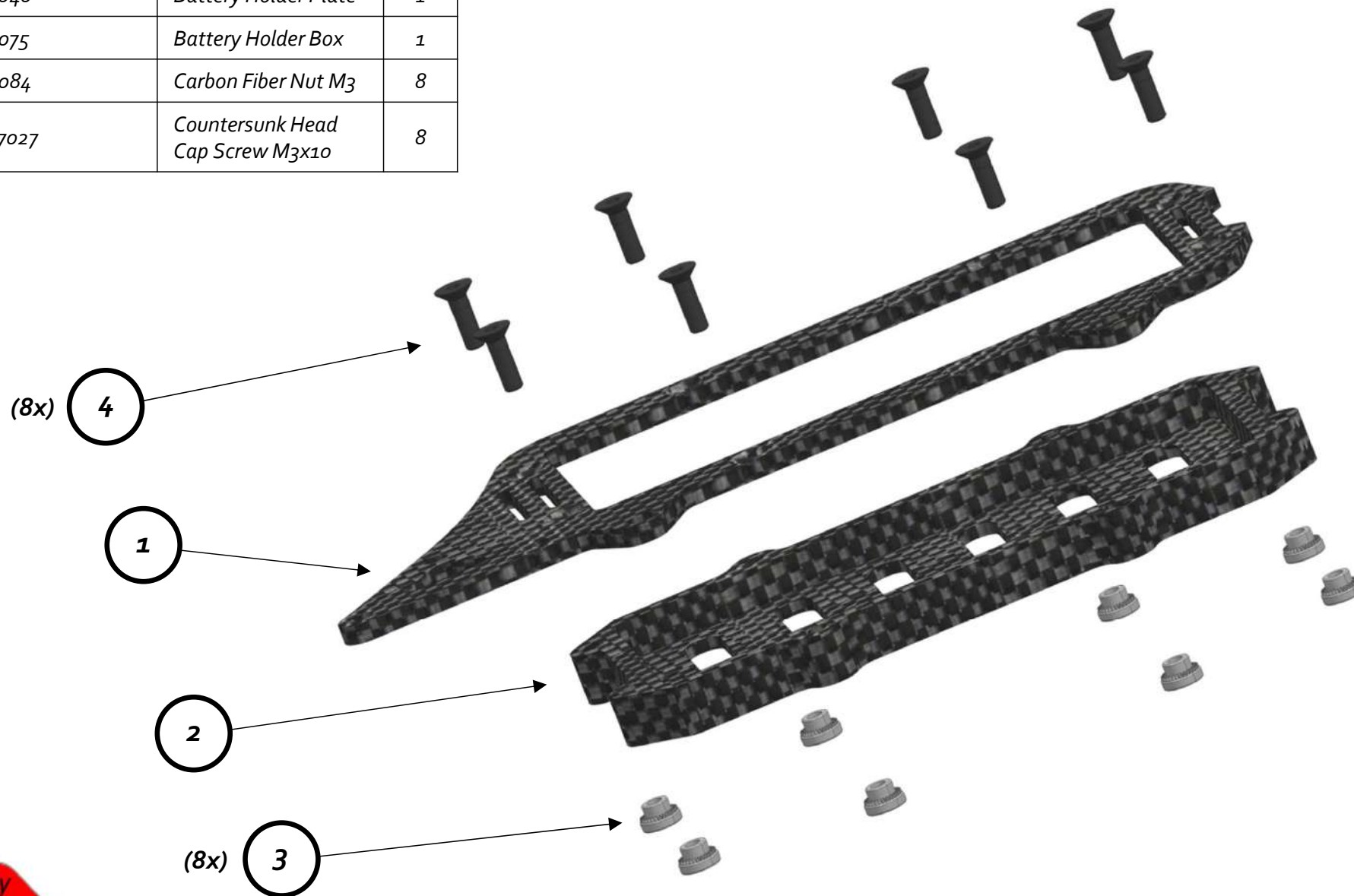

LATERAL RIGHT STIFFENER & BATTERY HOLDER MOUNTING

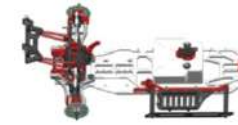

#	Code	Part Name	Qty
1	Cap 854	Flange Nut Self-locking M4	2
2	Cap 4117	Countersunk Head Cap Screw M4x14	2
3	Cap 4121	Countersunk Head Cap Screw M4x25	2

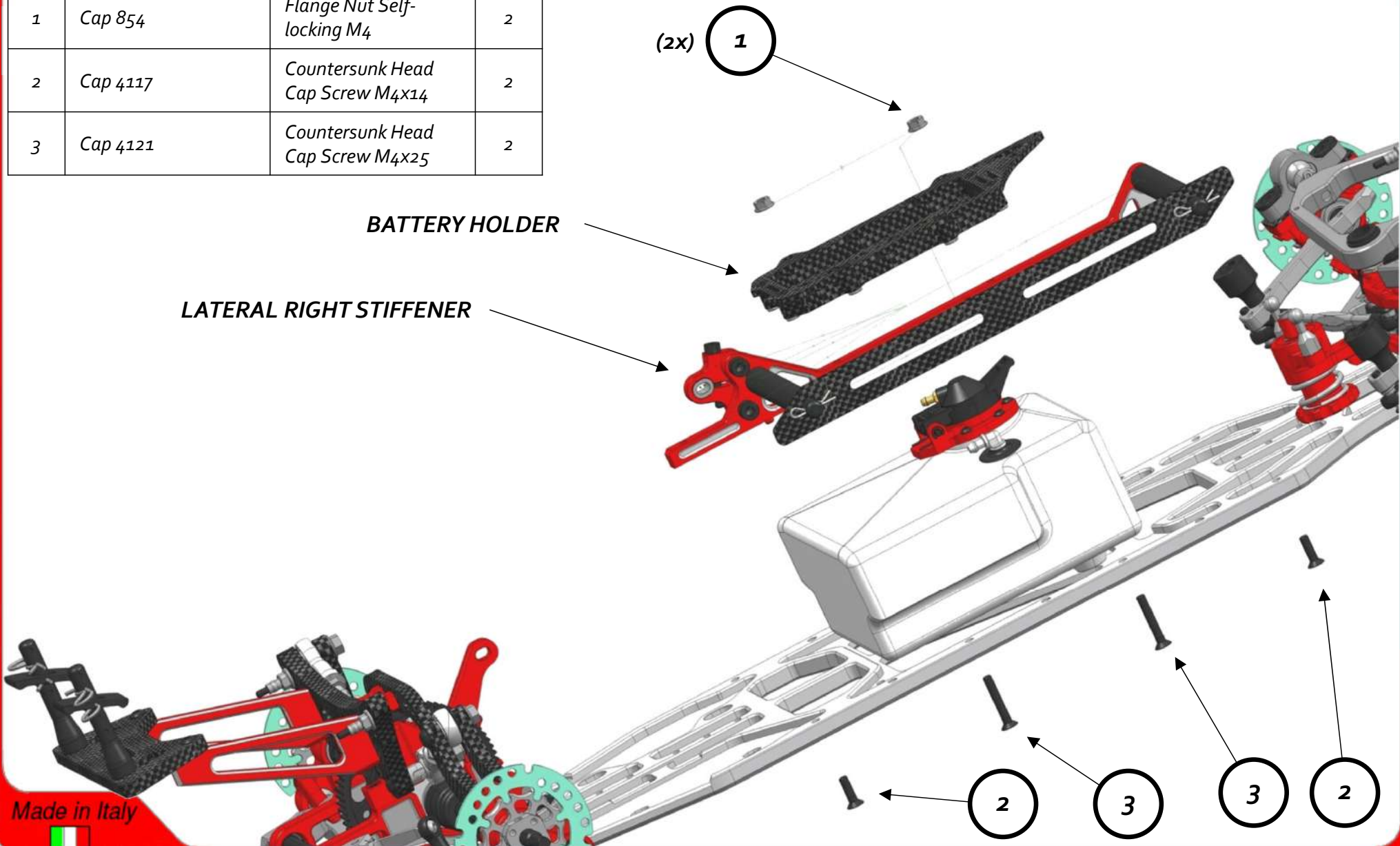

LATERAL LEFT STIFFENER



#	Code	Part Name	Qty
1	Cap 4004	Lateral Stiffener	1
2	Cap 4042	Lateral Protection	1
3	Cap 27002	Clip	2
4	Cap 4140	Lateral Body Holder Column Muffler Side	2
5	Cap 4113	Countersunk Head Cap Screw M4x16	2

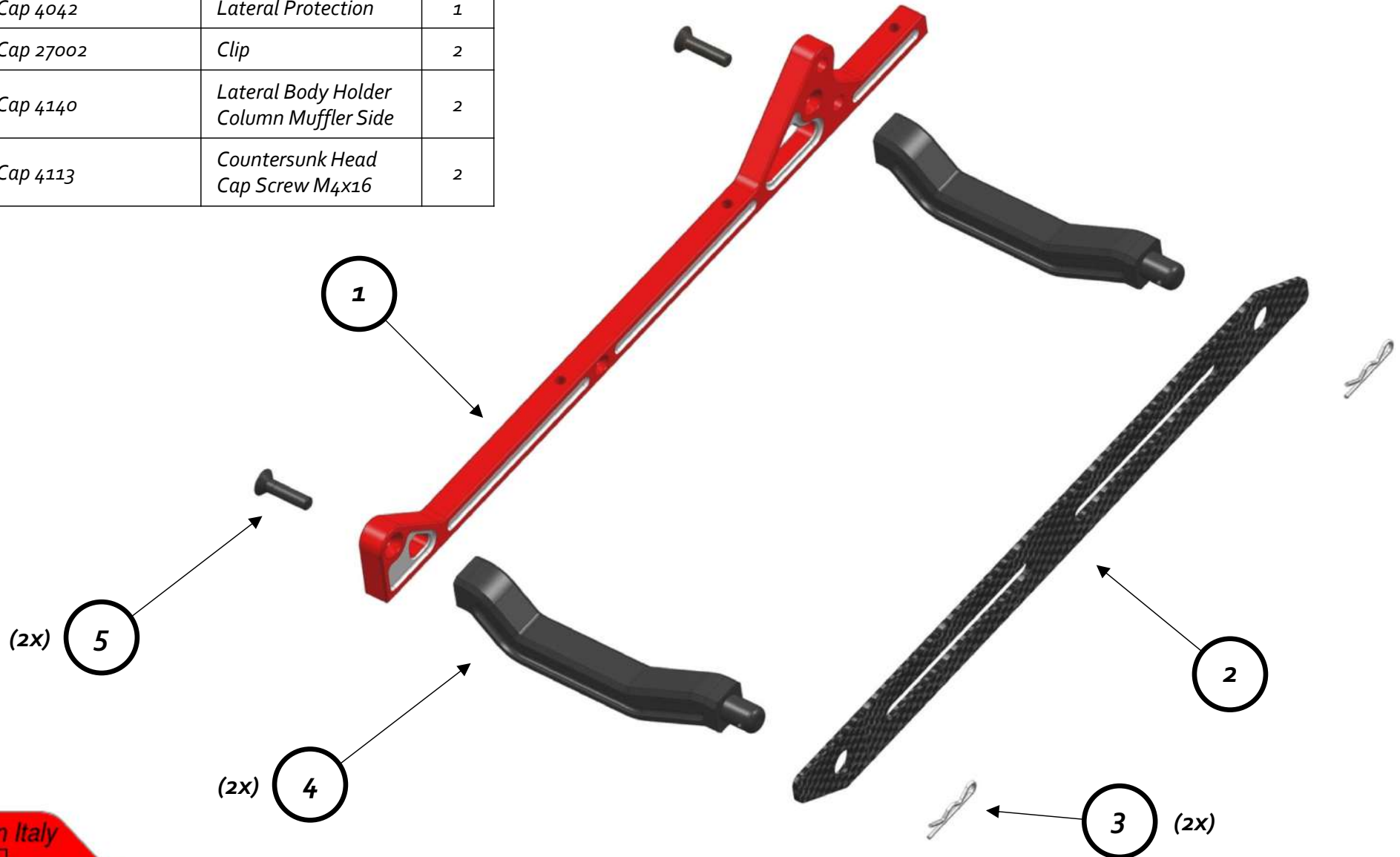



LATERAL LEFT STIFFENER & MUFFLER HOLDER MOUNTING

#	Code	Part Name	Qty
1	Cap 4041	Muffler Holder Plate	1
2	Cap 854	Flange Nut Self-locking M4	2
3	Cap 4117	Countersunk Head Cap Screw M4x14	2
4	Cap 4121	Countersunk Head Cap Screw M4x25	2

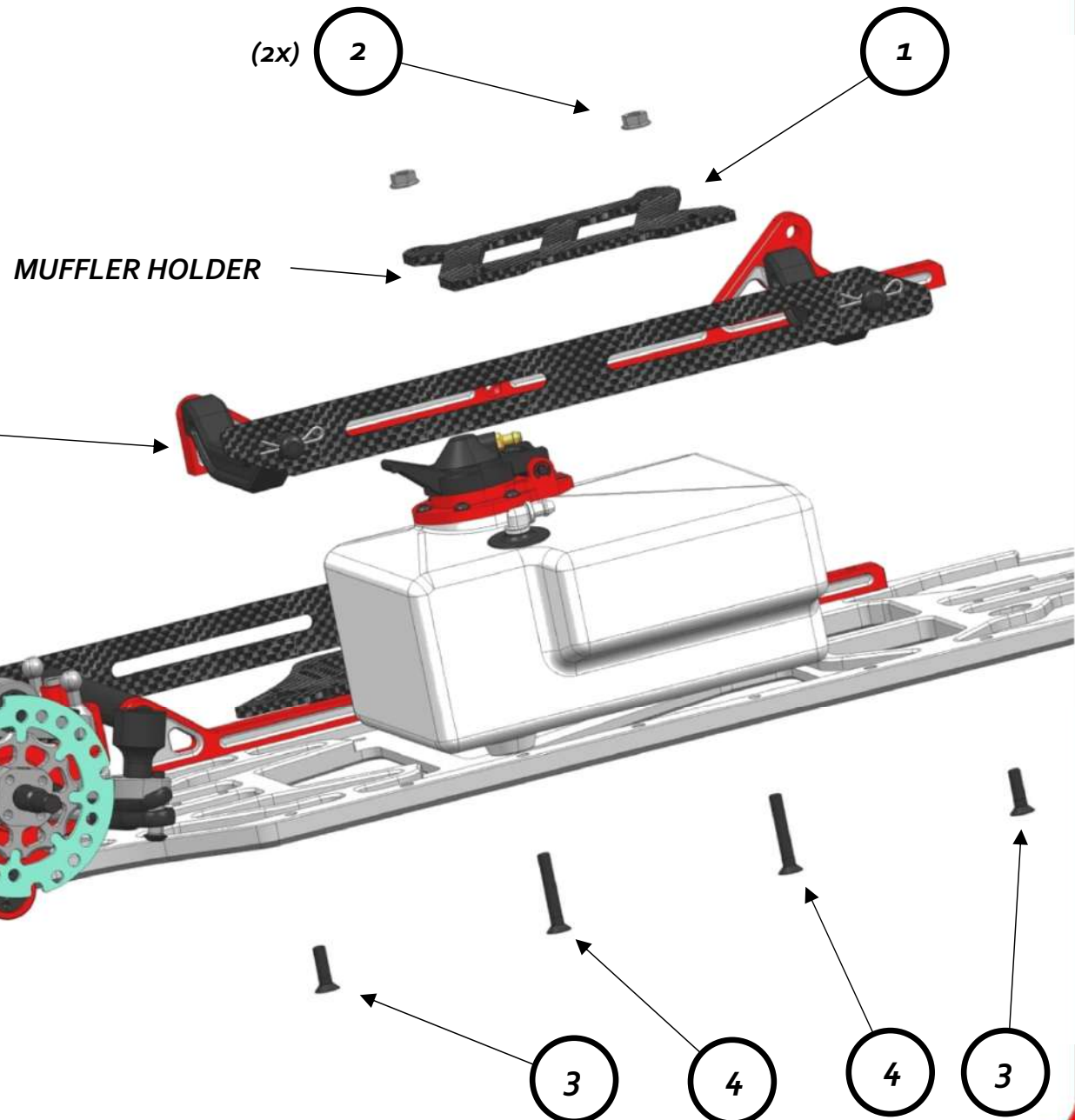

**SERVO PLATE &
RECEIVER BOX**



#	Code	Part Name	Qty
1	Cap 4033	Servo Plate	1
2	Cap 4058	Servo Saver Stiffener Spacer	1
3	Cap 17029	Countersunk Head Cap Screw M3x6	2

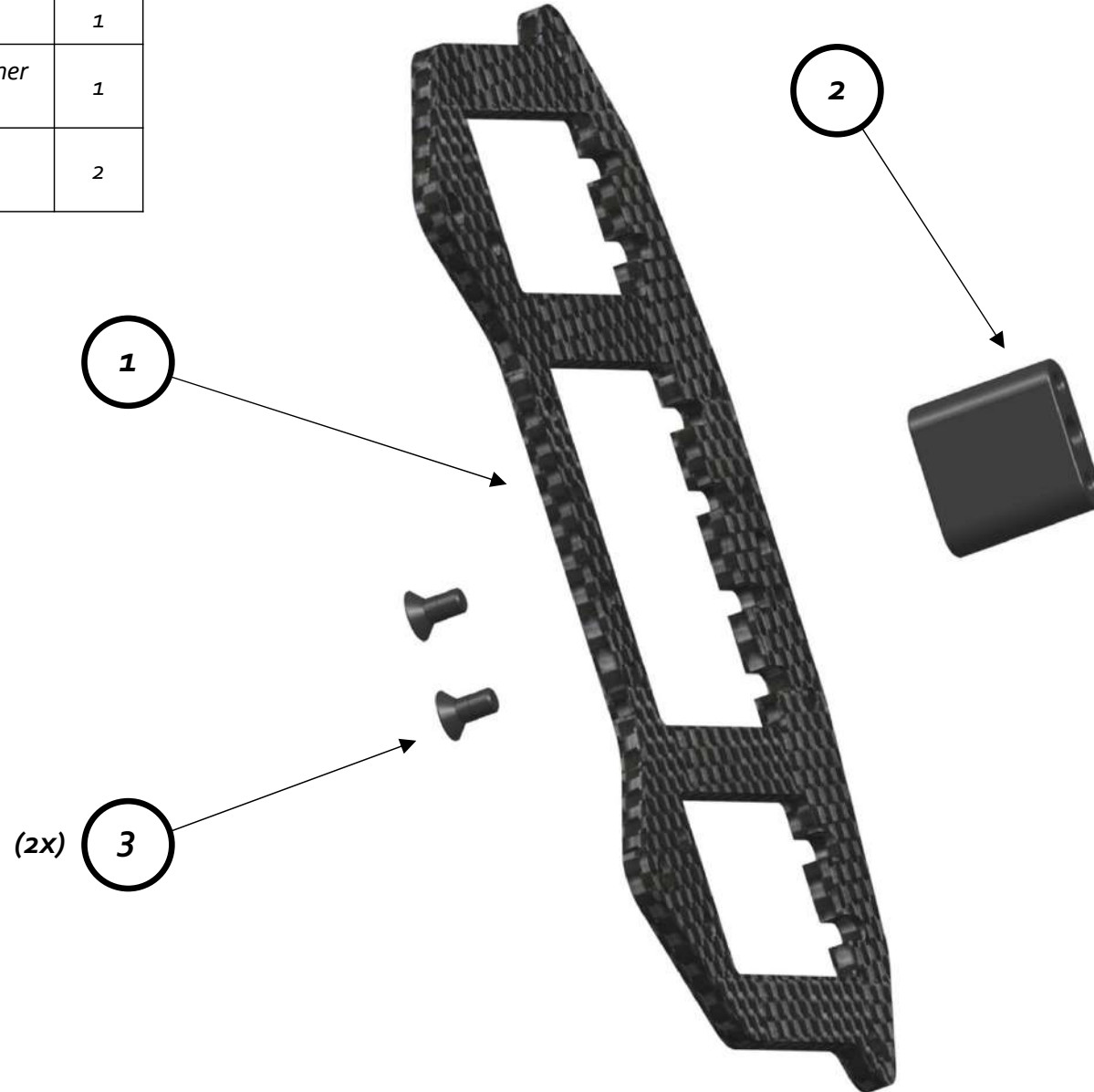

**SERVO PLATE &
RECEIVER BOX**



#	Code	Part Name	Qty
1	Cap 4155-K	Receiver Box	1
2	Cap 17040	Nut Self-locking M3	1
3	Cap 4147	Button Head Cap Screw M3x25	2

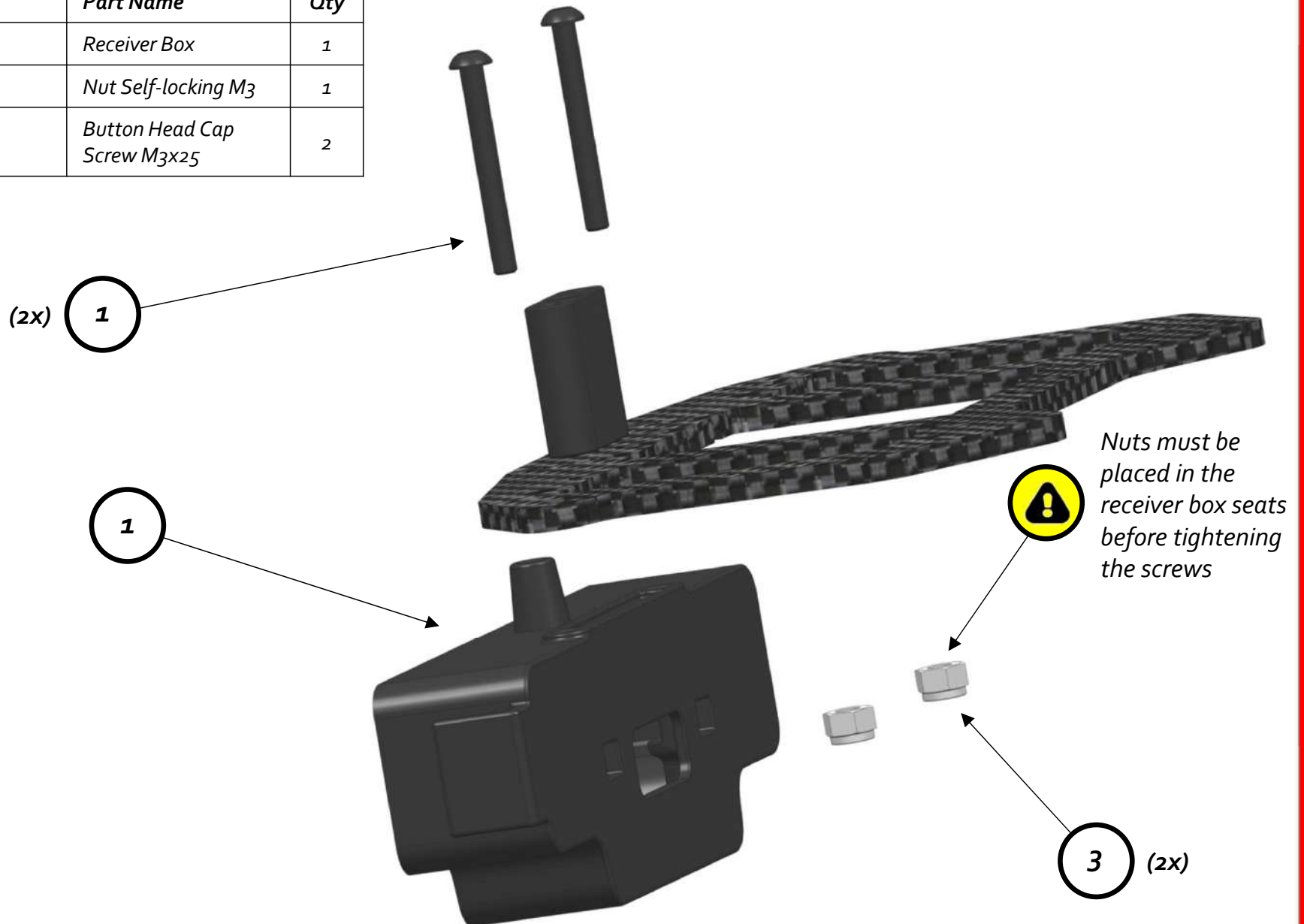

**SERVO PLATE &
RECEIVER BOX**



#	Code	Part Name	Qty
1	Cap 18086	Servo Bushing	16
2	Cap 17030	Button Head Cap Screw M3x6	16

(16x) **1**

**FOUR SERVOS
NOT INCLUDED**



(16x) **2**

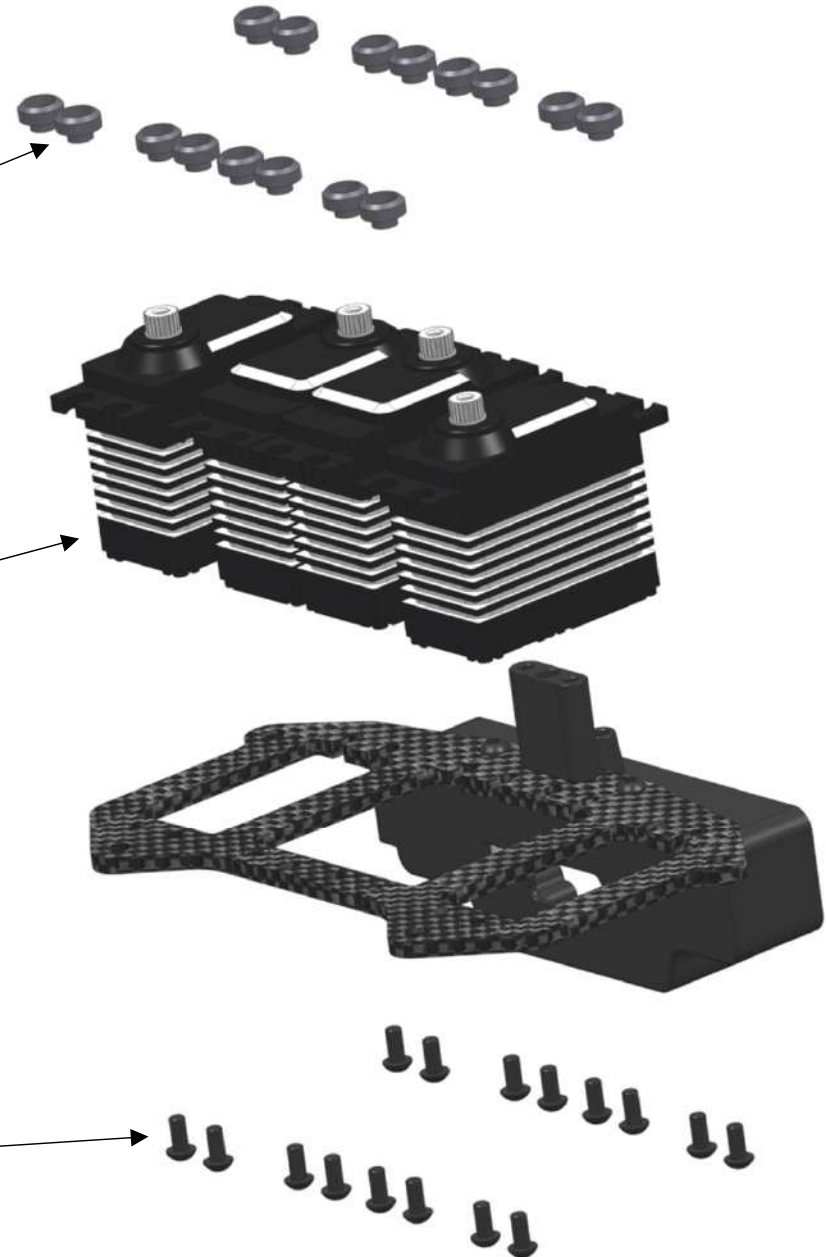

**SERVO PLATE &
RECEIVER BOX**



#	Code	Part Name	Qty
1	Cap 4155-K	Receiver Box Cover	1
2	Cap 17047	Countersunk Head Cap Screw M2x16	4
3	Cap 14001-5	Antenna Tube	1

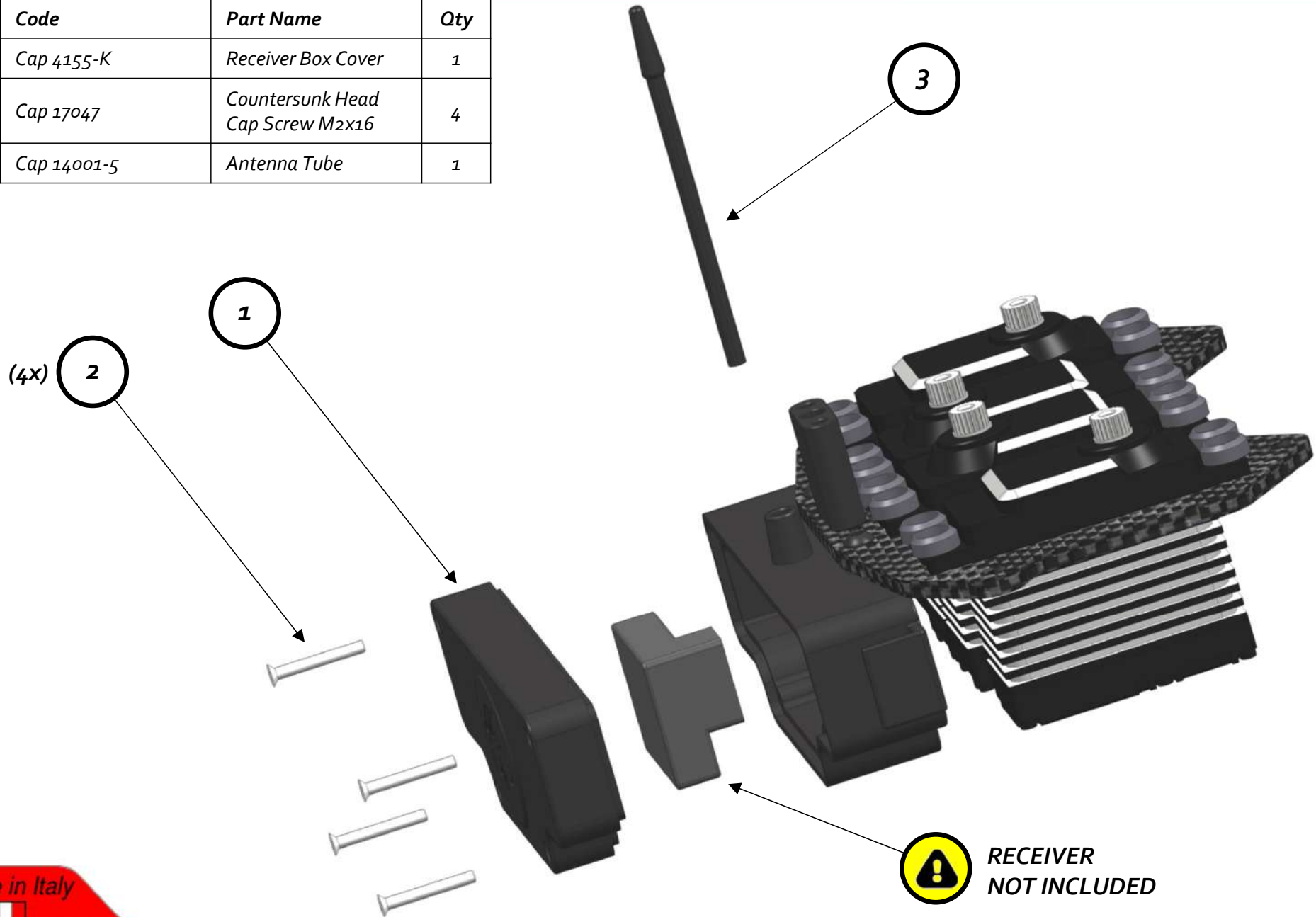

**RECEIVER
NOT INCLUDED**



**SERVO PLATE &
RECEIVER BOX**



#	Code	Part Name	Qty
1	Cap 4056	Column M4 30mm	4
2	Cap 4146	Button Head Cap Screw M4X10	4

(4x) **2**

(4x) **1**

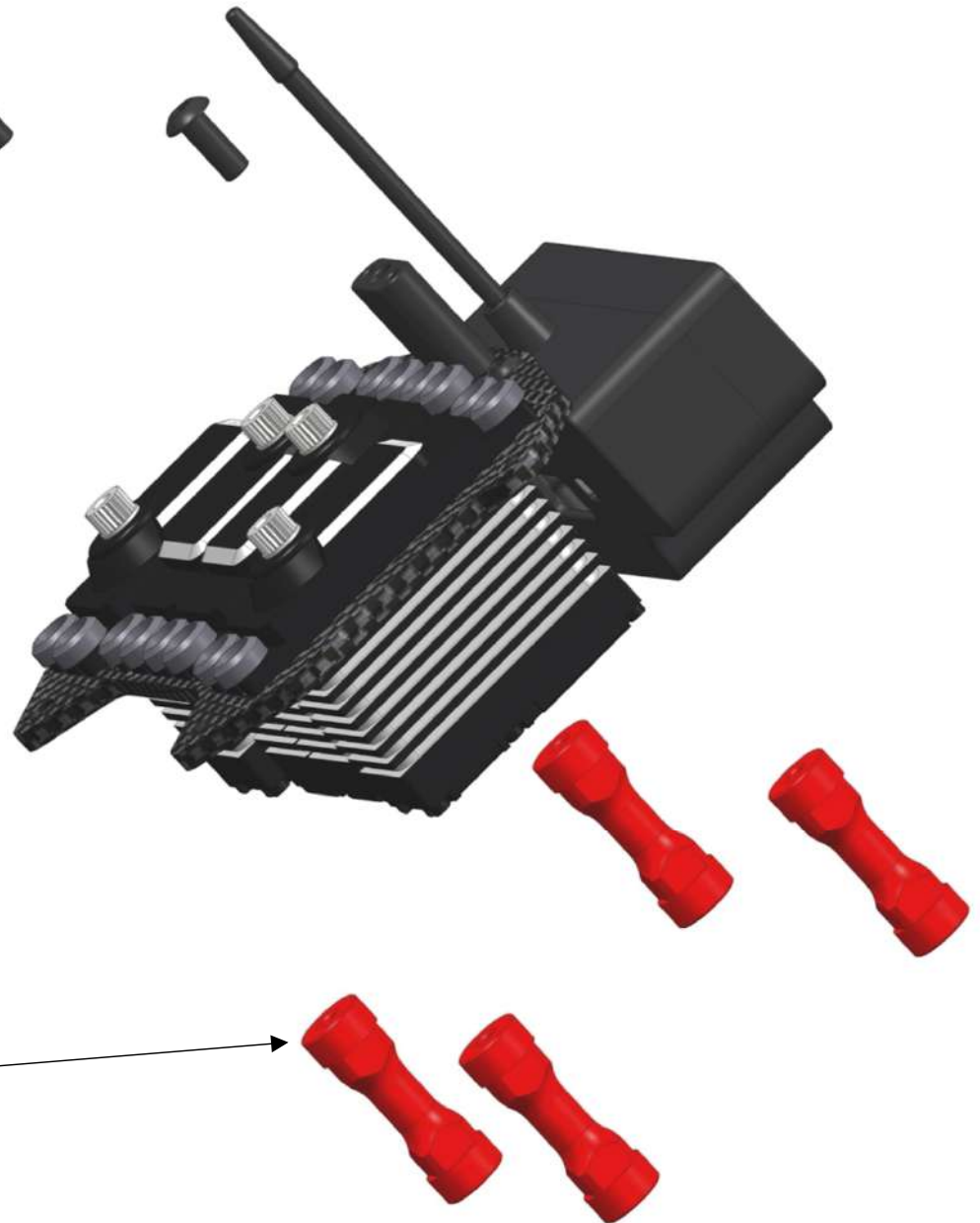

**SERVO PLATE &
RECEIVER BOX
MOUNTING**



#	Code	Part Name	Qty
1	Cap 2145	Countersunk Head Cap Screw M4x12	4

**SERVO PLATE &
RECEIVER BOX**

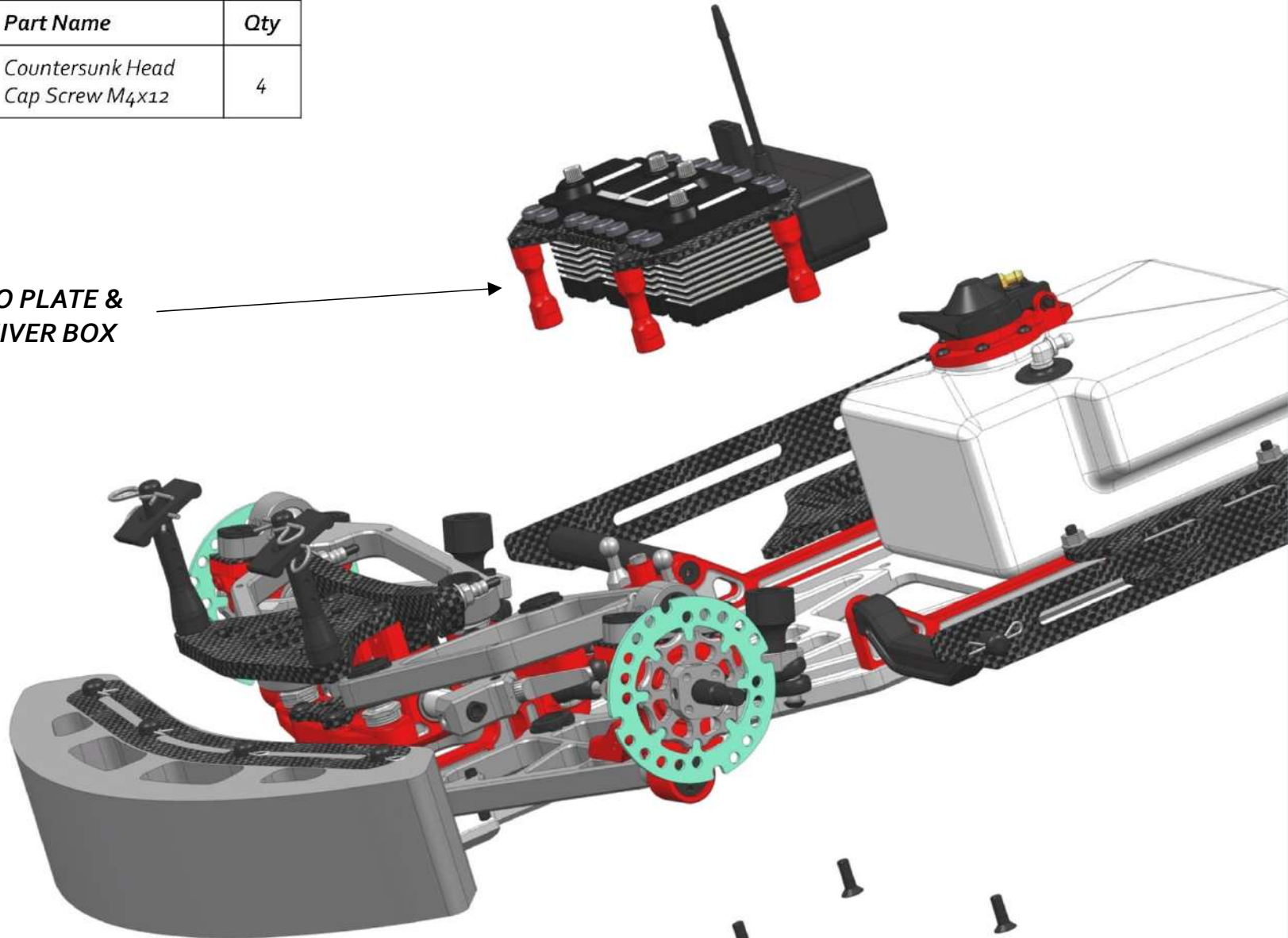

(4x) **1**





SERVO SAVER STIFFENER MOUNTING

#	Code	Part Name	Qty
1	Cap 4034	Servo Saver Stiffener	1
2	Cap 17031	Countersunk Head Cap Screw M3x8	2
3	Cap 2146	Countersunk Head Cap Screw M4x8	2
4	Cap 4146	Button Head Cap Screw M4X10	1

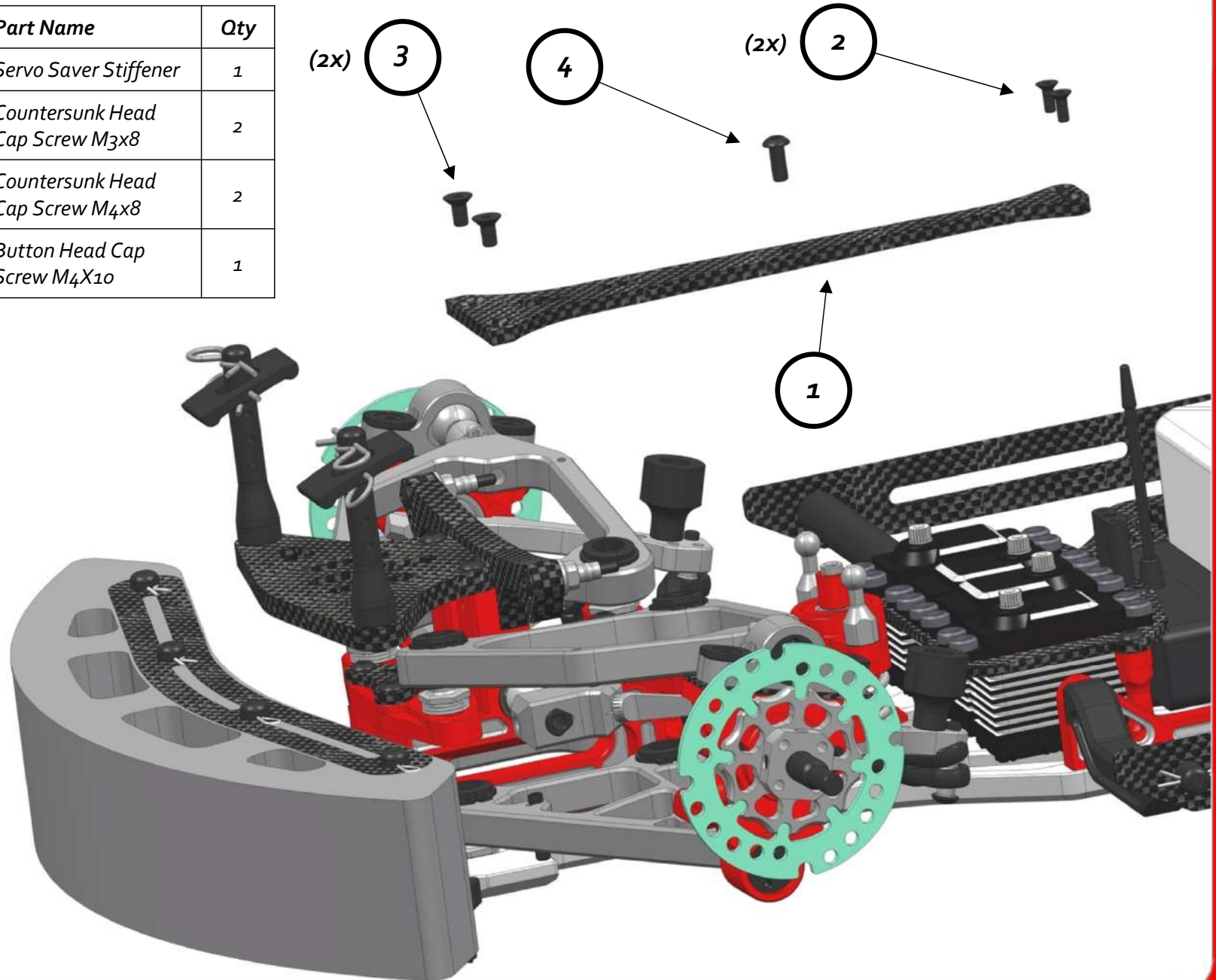



#	Code	Part Name	Qty
1	Cap 3127	Shock Body	4
2	Cap 3140	Shock Seal O-Ring	4
3	Cap 3138 K	Shock Seal Washer 3.6X7X2.5	8
4	Cap 3138 K	Shock Seal O-Ring	8
5	Cap 3138 K	Shock Seal Washer 3.5X7X1.0	4
6	Cap 3128	Shock Seal Cap	4

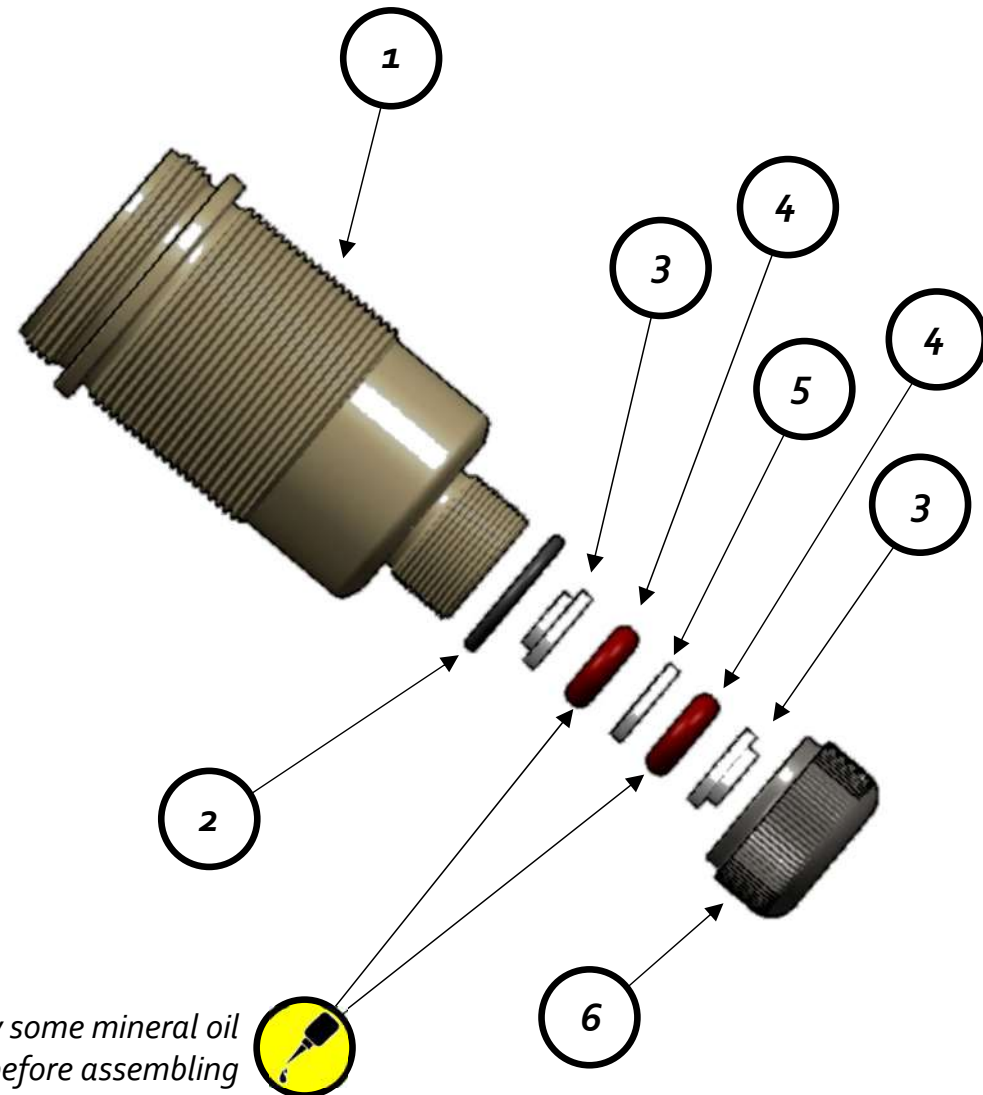

**FRONT & REAR SHOCK
ABSORBERS**



#	Code	Part Name	Qty
1	Cap 3134	Teflon Coated Shock Shaft	4
2	Cap 3143	Shim 2.6x6x0.6	4
3	Cap 3133	Shock Piston 1.2X8Holes	4
4	Cap 17039	Self-locking Nut M2.5	4

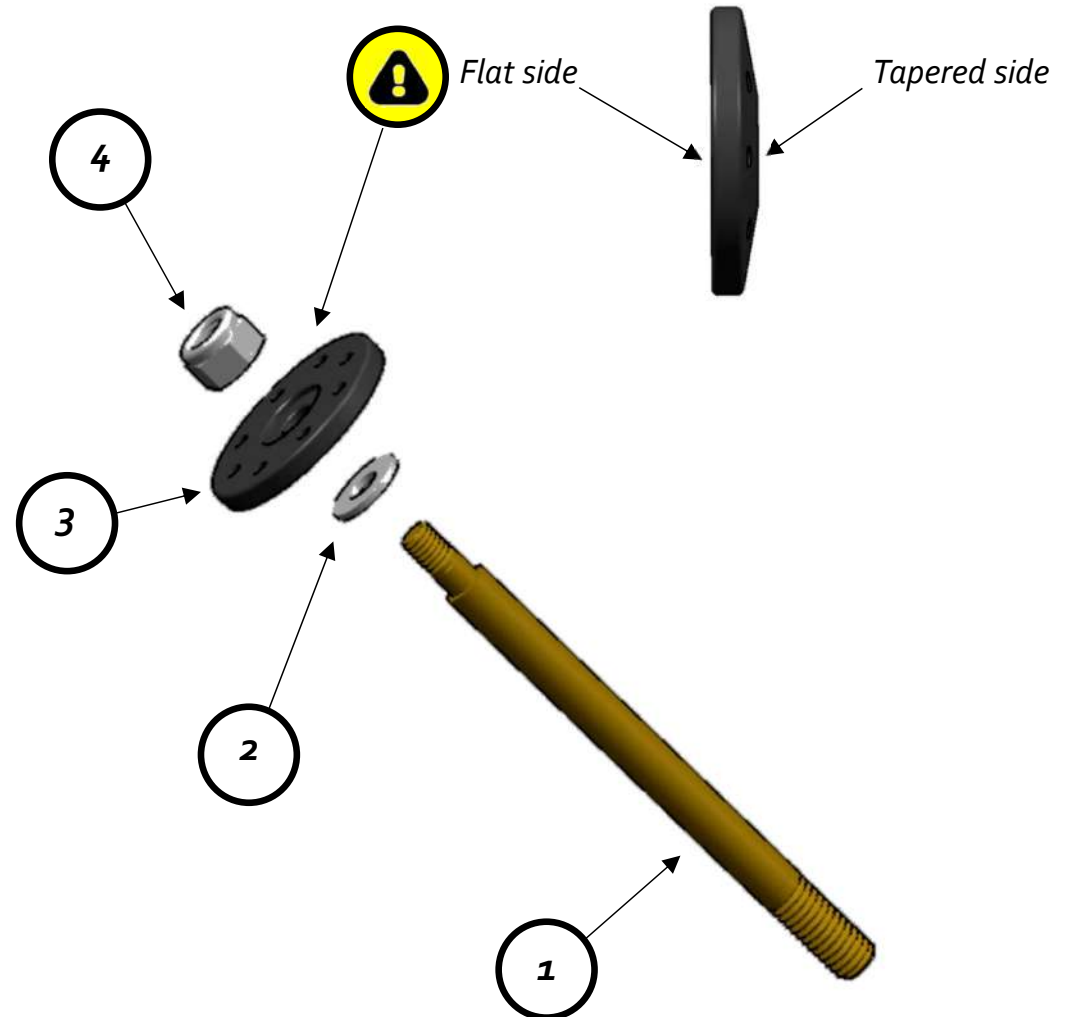



#	Code	Part Name	Qty
1	Cap 4168	Shock Uniball	4

Measure with the shock shaft fully extended



DEFAULT SETUP
FRONT: 24.0mm
REAR: 24.0mm

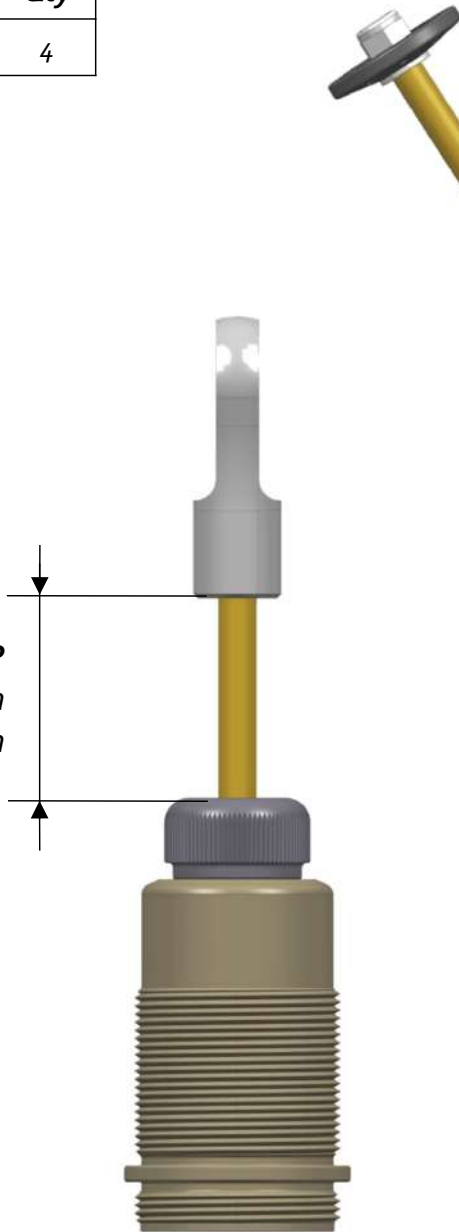

Apply some mineral oil before assembling

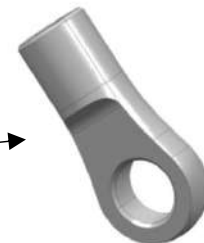
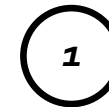

**FRONT & REAR SHOCK
ABSORBERS**



#	Code	Part Name	Qty
1	Cap 3129 K	Shock Spring Adjust Nut	4
2	Cap 3129 K	Shock Spring Adjust Nut O-Ring	4

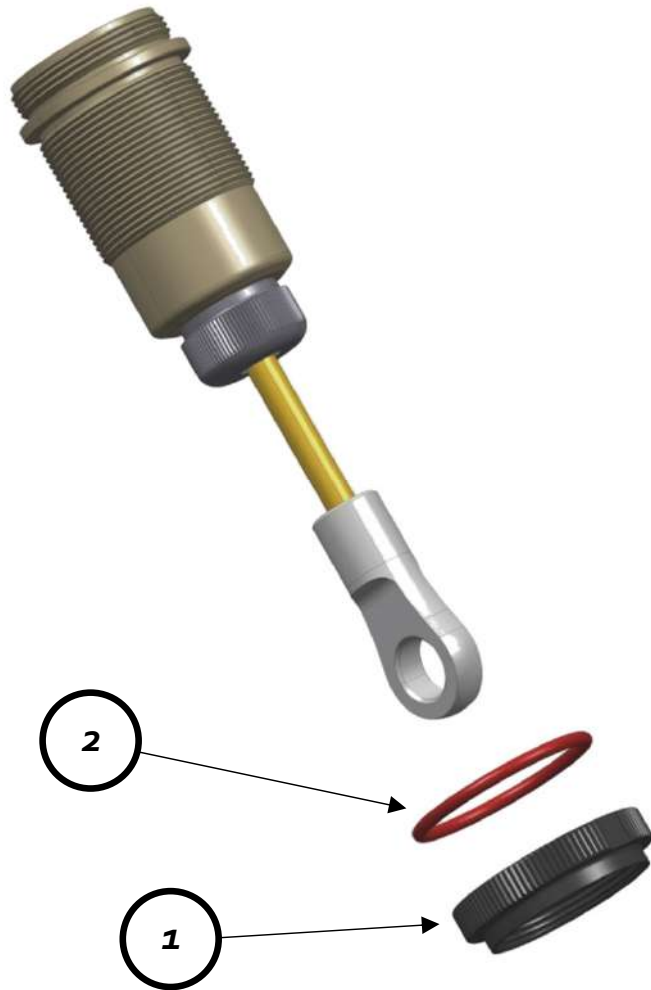

FILL SHOCK AS FOLLOWS

1. Extend the shock shaft completely
2. Fill up the shock body fully with silicone oil (not included)
3. Move the shock shaft slowly up and down to let all air bubbles escape from oil



DEFAULT SETUP

FRONT: 1000cSt
REAR: 1000cSt



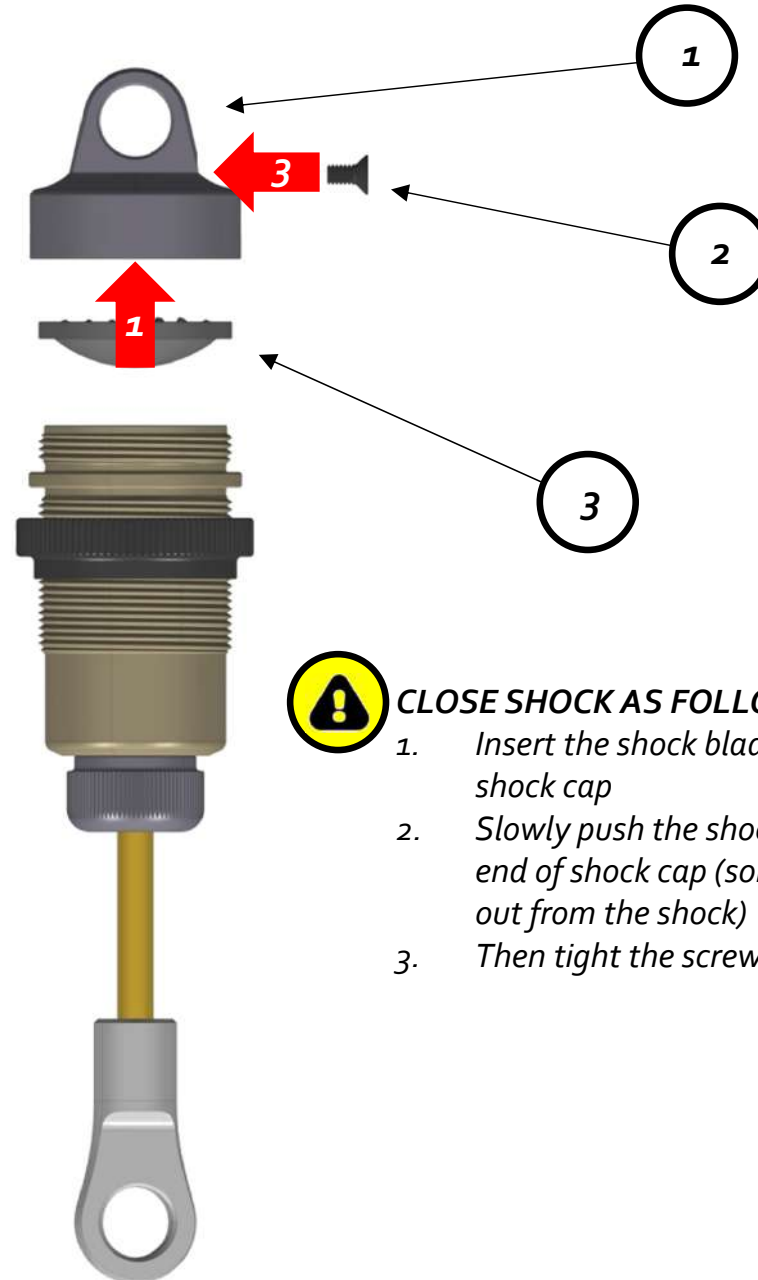

#	Code	Part Name	Qty
1	Cap 3131 K	Shock Cap	4
2	Cap 3131 K	M2.0x4.6 HEX Screw	4
3	Cap 3132	Shock Bladder	4

**CLOSE SHOCK AS FOLLOWS**

1. Insert the shock bladder into the shock cap
2. Slowly push the shock shaft up to the end of shock cap (some oil could leak out from the shock)
3. Then tight the screw M2.0x4.6



FRONT & REAR SHOCK ABSORBERS

Capricorn RC
BUILD 4X L/R



#	Code	Part Name	Qty
1	Cap 3131 K	Shock Cap Ball Bushing	4
2	Cap XXXX	Front Spring	2
3	Cap XXXX	Rear Spring	2
4	Cap 3135	Shock Spring Holder	4
5	Cap 4169	Shock Absorber Uniball Sphere Bushing	4

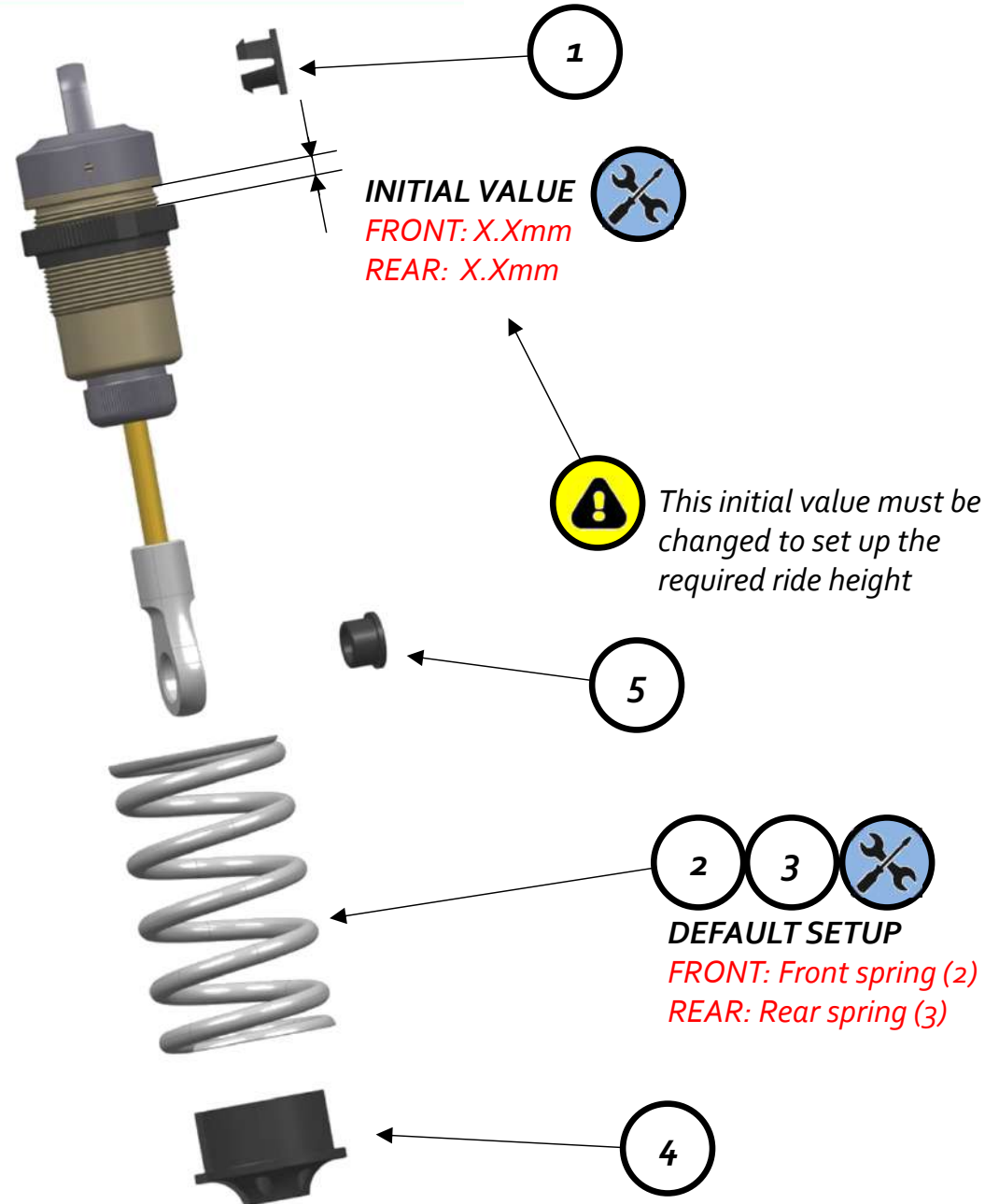

SHOCK ABSORBERS MOUNTING



#	Code	Part Name	Qty
1	Cap 4164	Shock Absorber Uniball Sphere	2
2	Cap 17025	Button Head Cap Screw Flange M3x12	2
3	Cap 2547	Flange Nut Self-locking M3	2

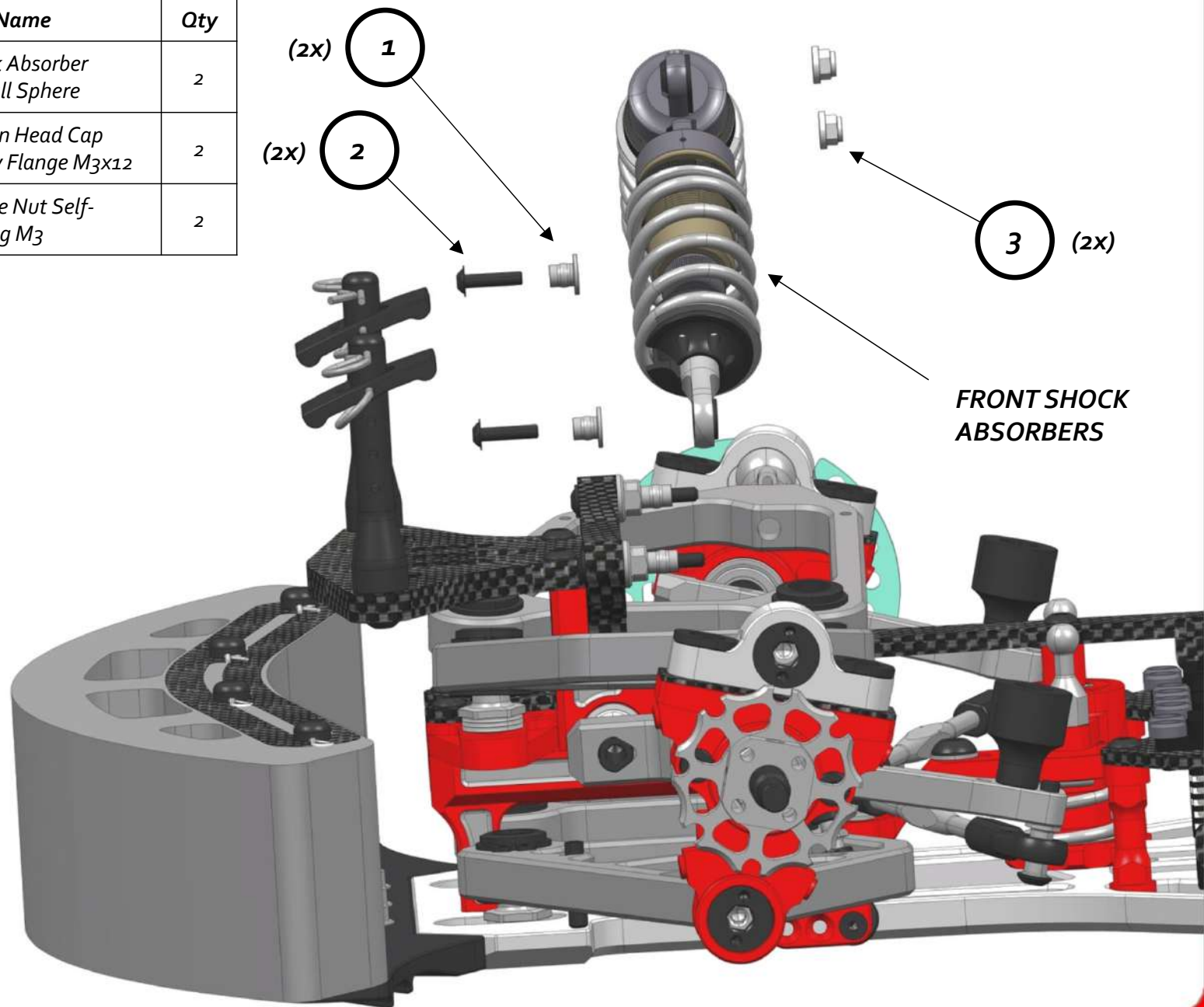

SHOCK ABSORBERS MOUNTING



#	Code	Part Name	Qty
1	Cap 4164	Shock Absorber Uniball Sphere	2
2	Cap 17025	Button Head Cap Screw Flange M3x12	2
3	Cap 2547	Flange Nut Self-locking M3	2

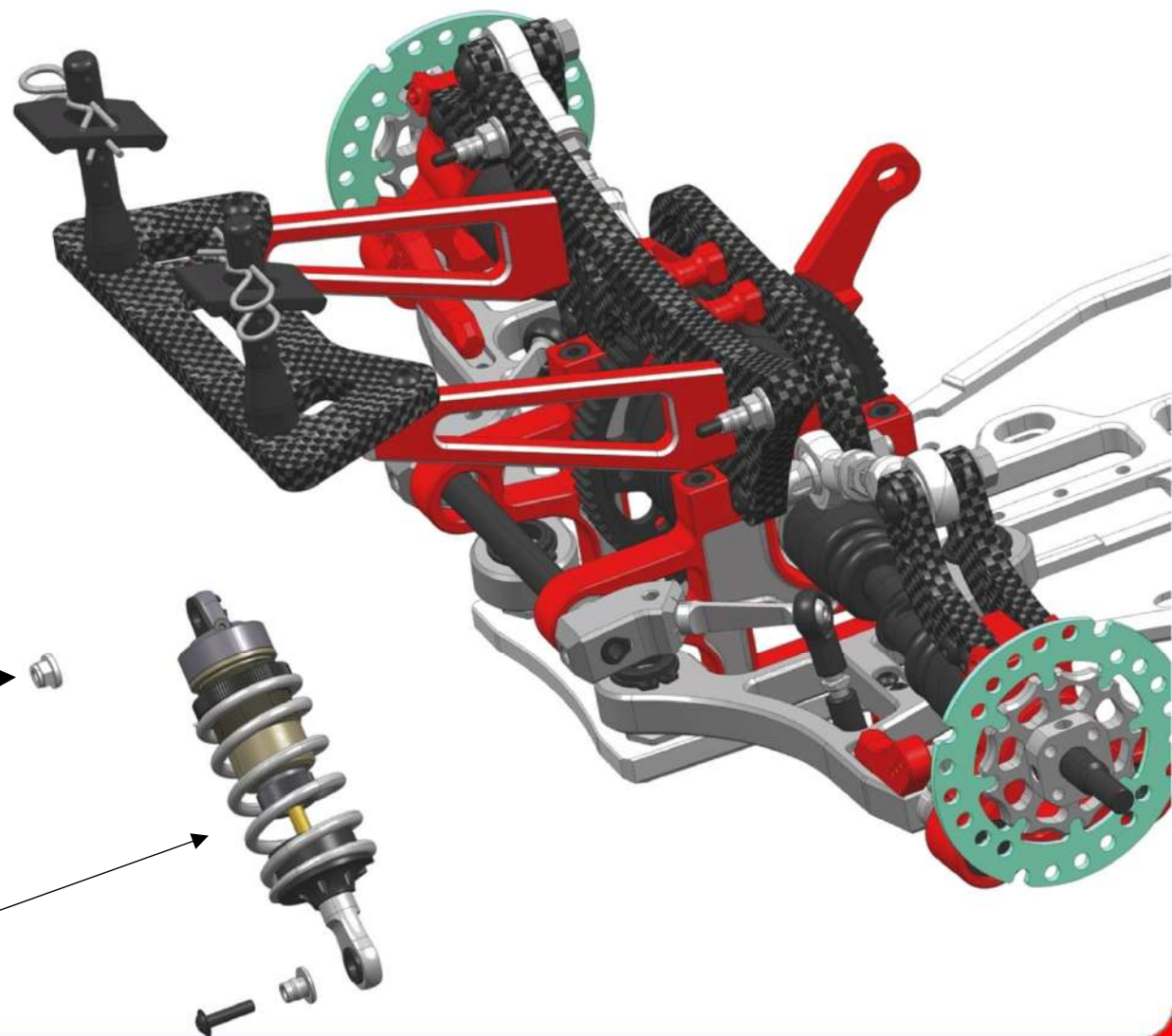
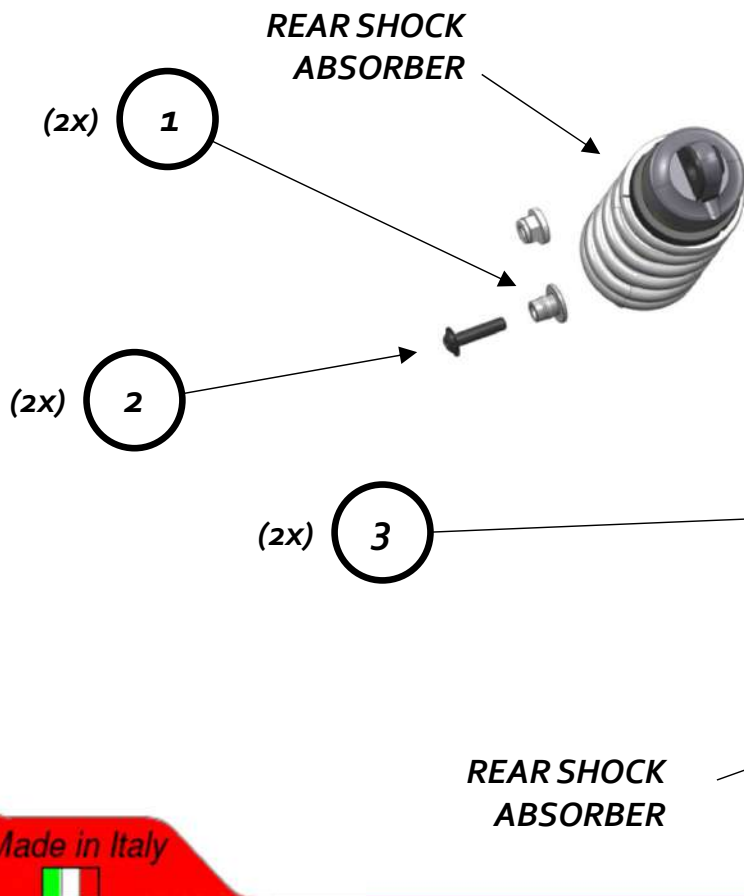

**TRANSMISSION
MOUNTING**

#	Code	Part Name	Qty
1	Cap 4133	Transmission Shaft	1
2	Cap 4135	Differential Pignon 24T	1
3	Cap 2129	Shaft Seeger Ring 12mm	2

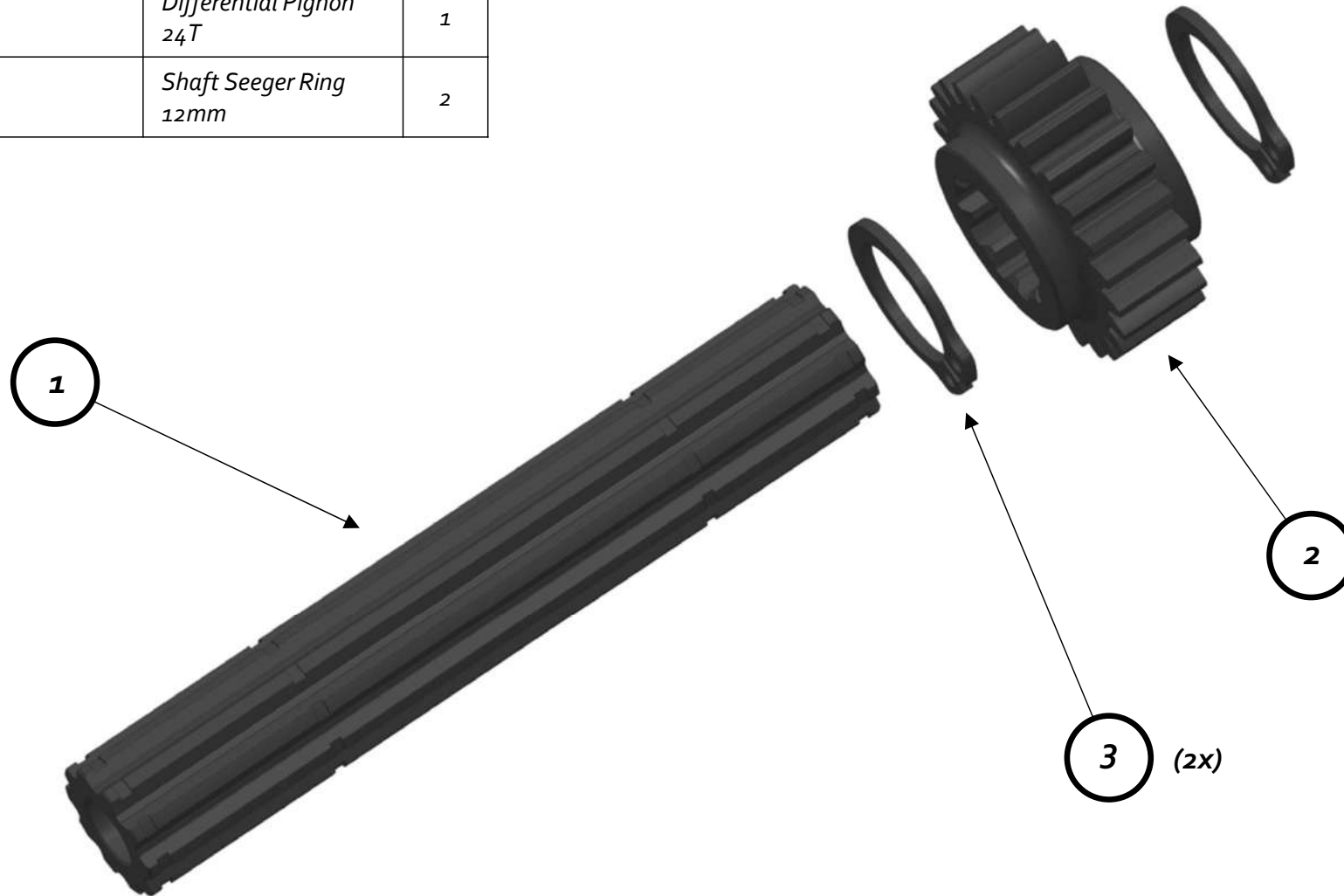

TRANSMISSION MOUNTING



#	Code	Part Name	Qty
1	Cap 4009	Transmission Support	1
2	Cap 4028	Bearing 12x21x5 61801 ZZ	2

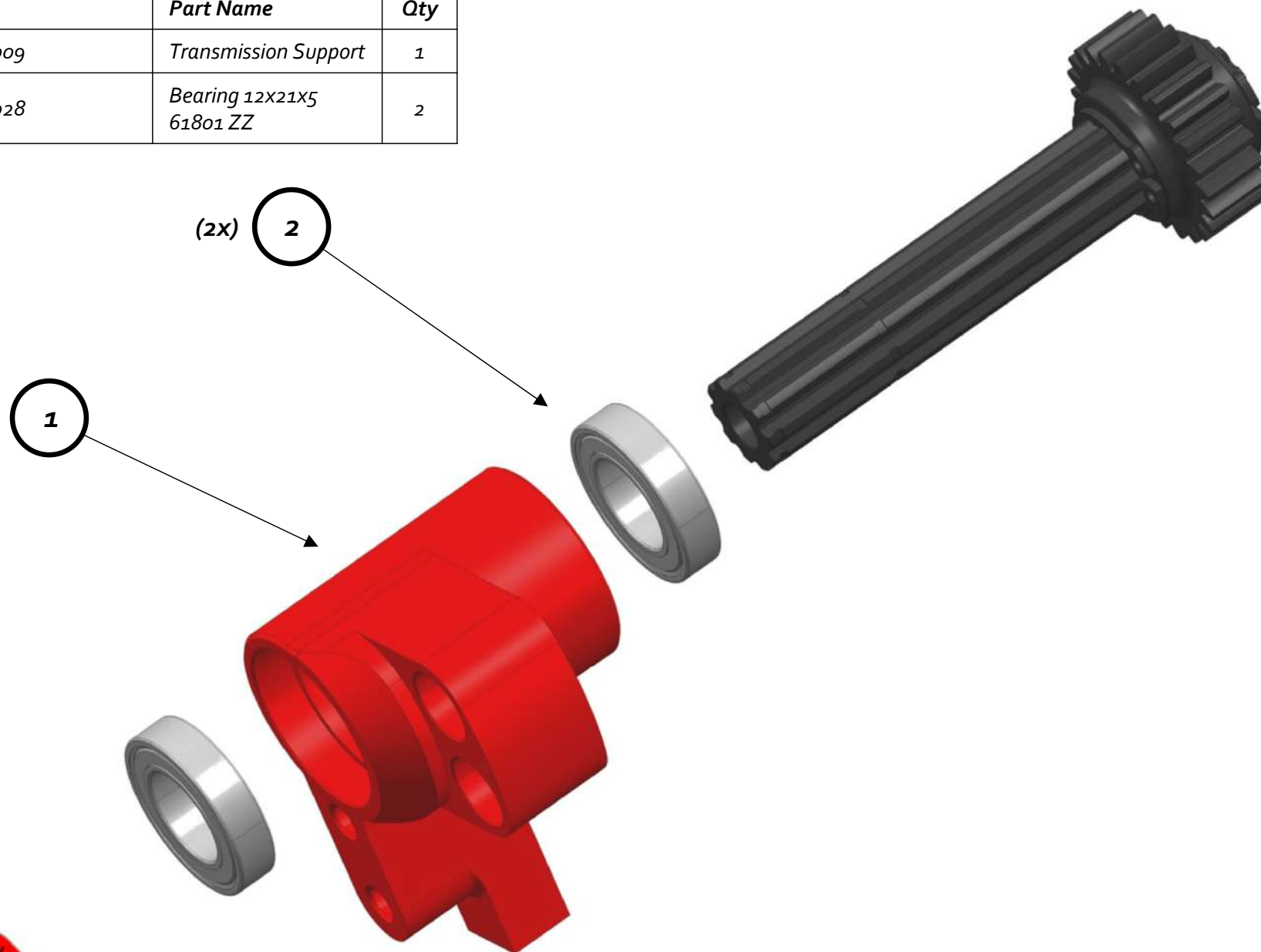

TRANSMISSION MOUNTING



#	Code	Part Name	Qty
1	Cap 4132	Cylindrical Head Cap Screw M5x16	2
2	'Cap 4117	Countersunk Head Cap Screw M4x14	1

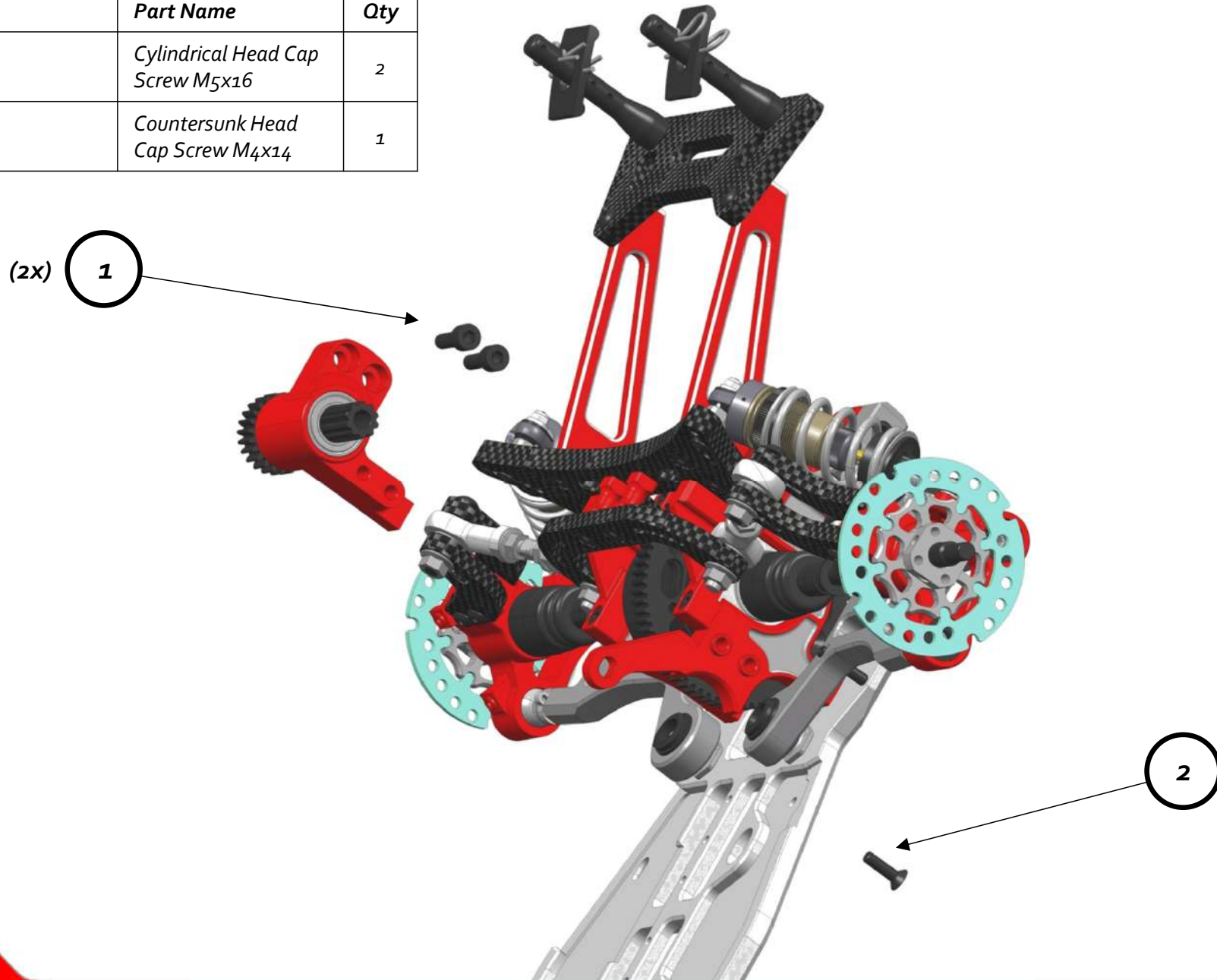

TRANSMISSION MOUNTING



#	Code	Part Name	Qty
1	Cap 4039	Later Engine Stiffener	1
2	Cap 4170	Countersunk Head Cap Screw M5x12	2
3	Cap 4132	Countersunk Head Cap Screw M5x12	2

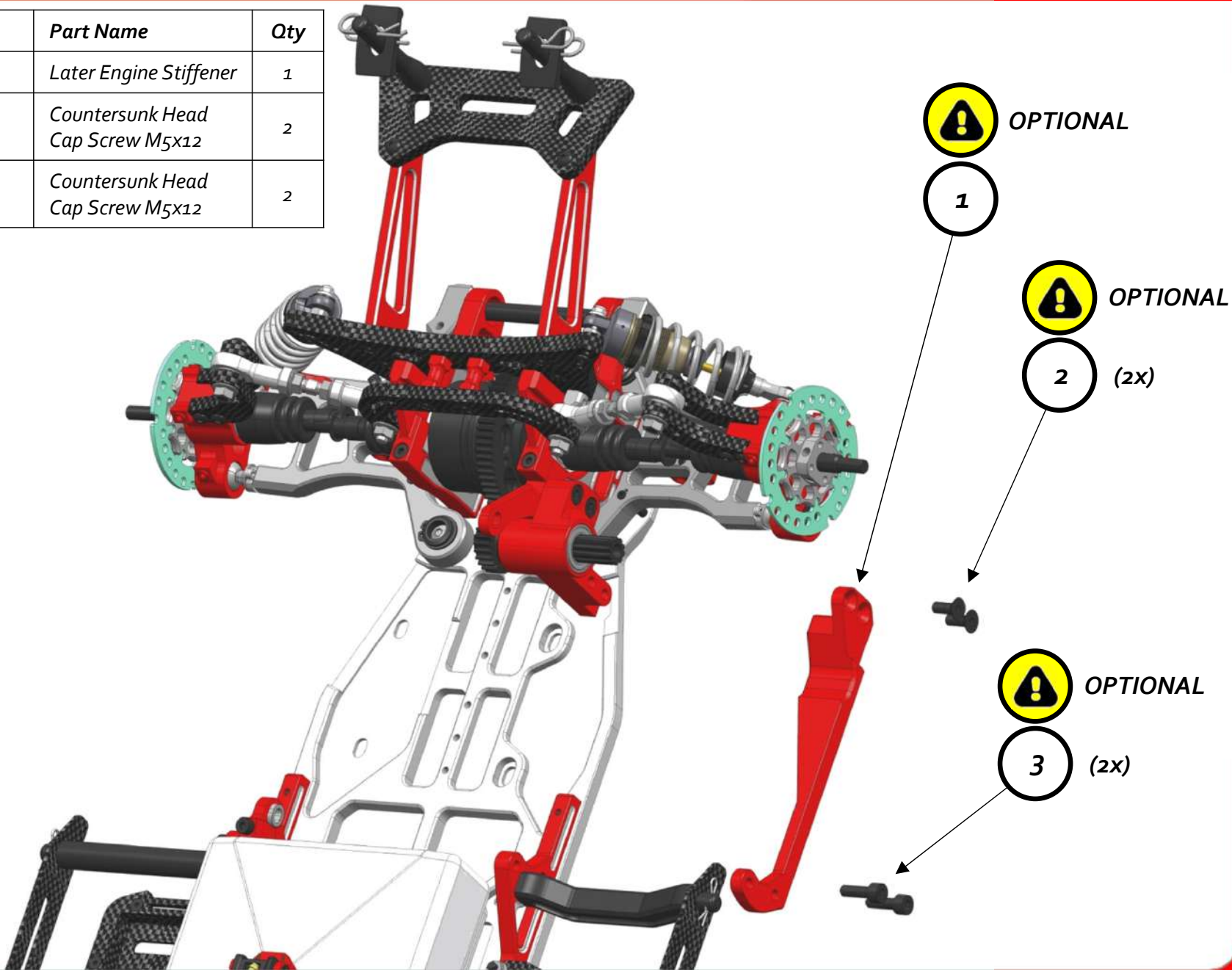



#	Code	Part Name	Qty
1	Cap 4134	Crown Gear 64T	1
2	Cap 2129	Shaft Seeger Ring 12mm	2

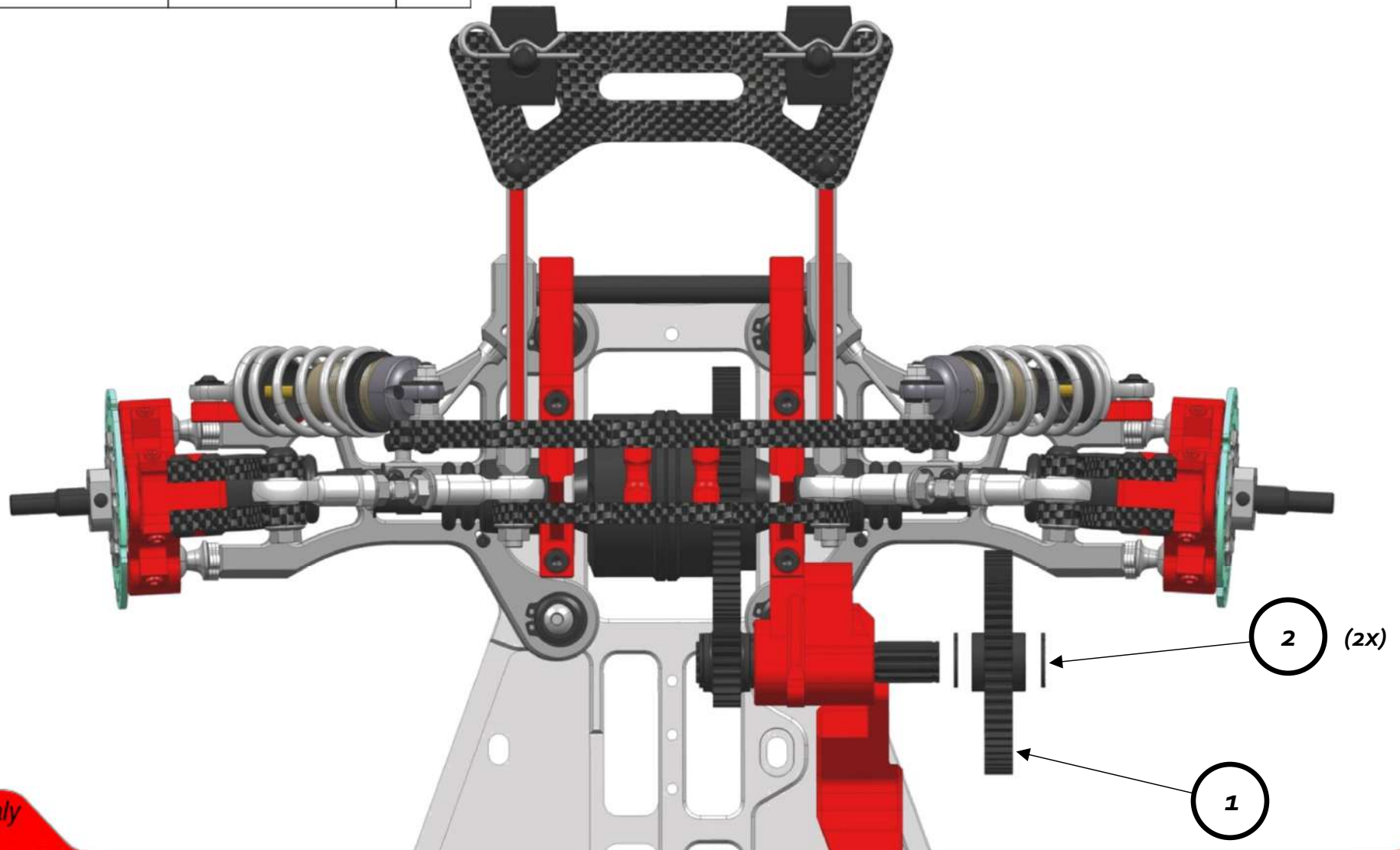



#	Code	Part Name	Qty
1	Cap 3217	Turnbuckle M4x28	2
2	Cap 2361	Uniball Link 7mm	2
3	Cap 3179	Uniball Link 7mm Long	2

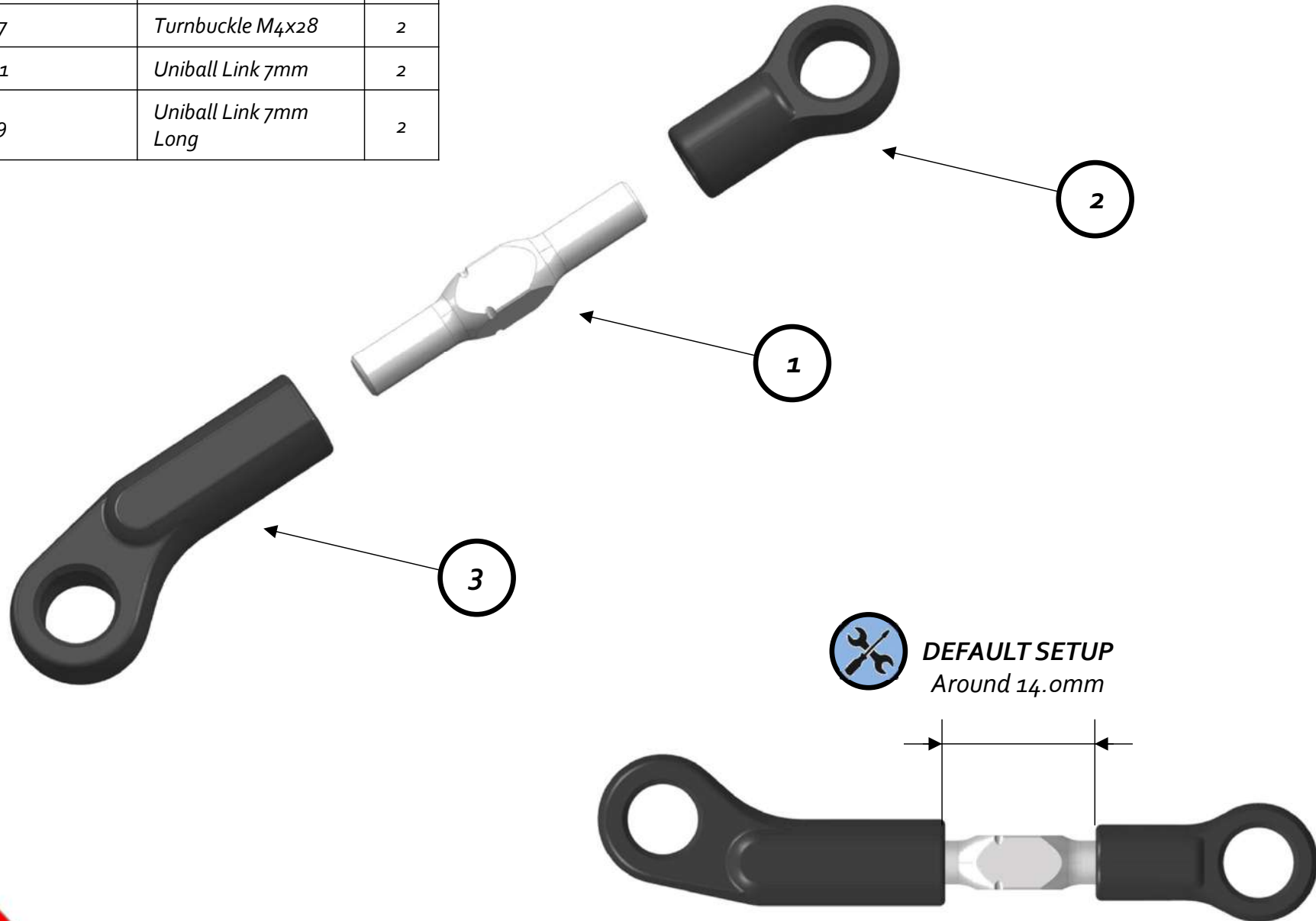

SERVO STEERING LINKS MOUNTING



#	Code	Part Name	Qty
1	Cap 4102	Servo Horn	2
2	Cap 17030	Button Head Cap Screw M3x6	2
3	Cap 2237	Uniball 7mm	2
4	Cap 17032	Button Head Cap Screw M3x8	2

SERVO STEERING LINKS

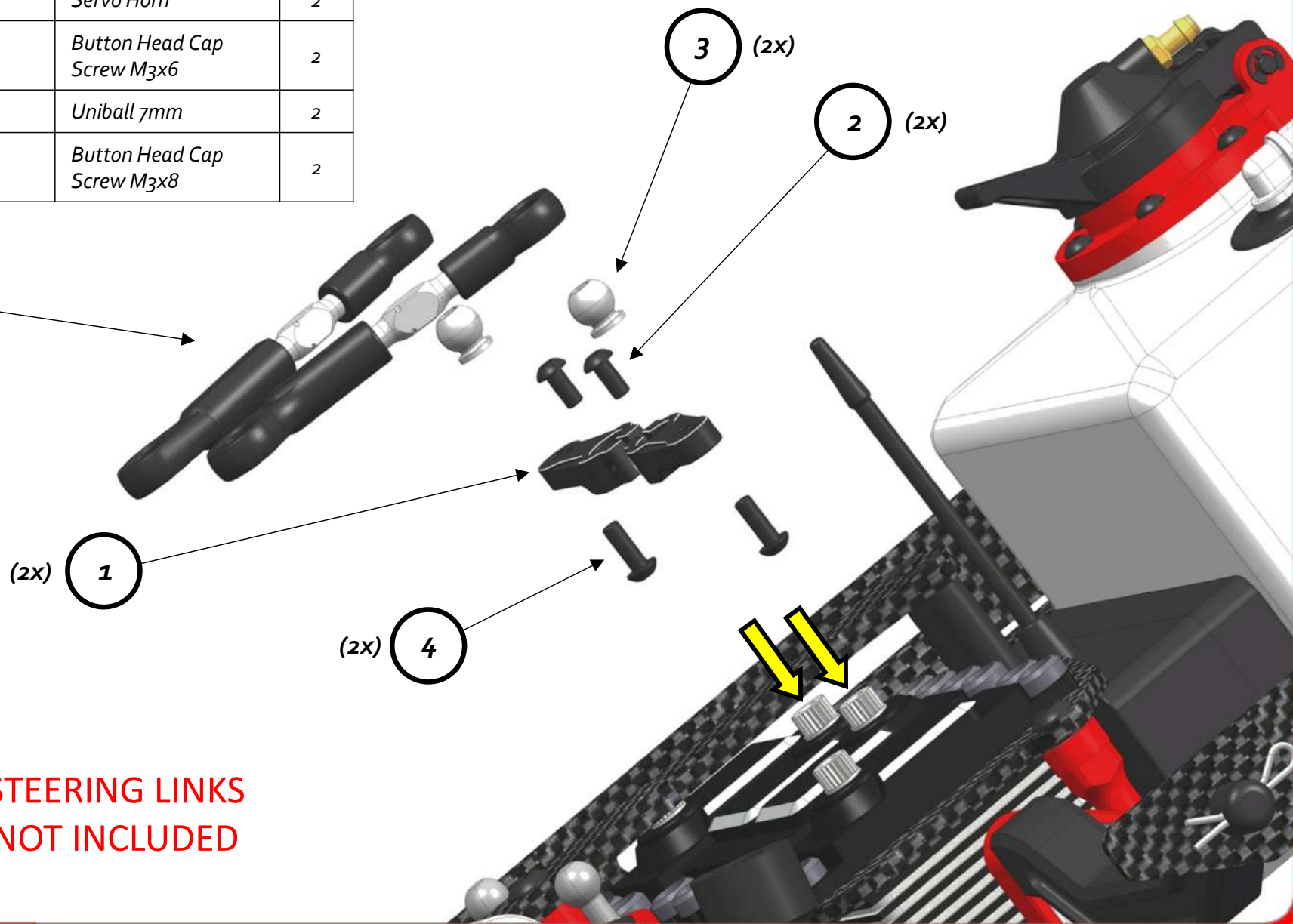

STEERING LINKS NOT INCLUDED



LEFT BRAKE & THROTTLE LINK



#	Code	Part Name	Qty
1	Cap 4103	Throttle Extension Lever	1
2	Cap 4102	Servo Horn	1
3	Cap 2631	Throttle Brake T Joint	2
4	Cap 17040	Self-locking Nut M3	2
5	Cap 16015	Collar	8
6	Cap 17006	Grub Screw M3x3	8
7	Cap 17028	Button Head Cap Screw M3x16	1
8	Cap 4173	Button Head Cap Screw M3x20	1
9	Cap 17041	Throttle Spring	1
10	Cap 4105	Brake Linkage	1
11	Cap 4106	Throttle Linkage	1

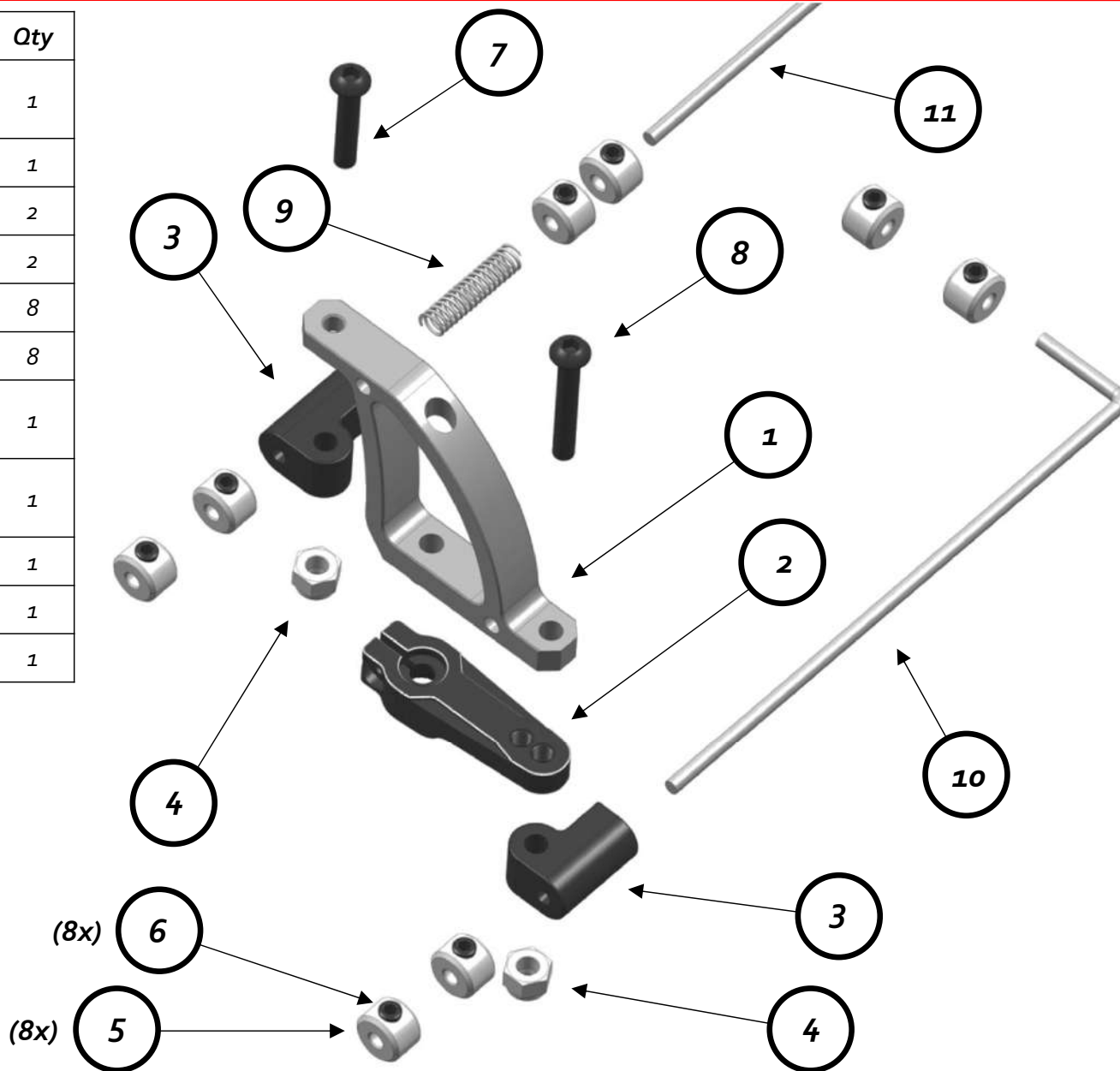

**STEERING LINKS
NOT INCLUDED**





RIGHT BRAKE LINK

#	Code	Part Name	Qty
1	Cap 4102	Servo Horn	1
2	Cap 2631	Throttle Brake T Joint	1
3	Cap 17040	Self-locking Nut M3	1
4	Cap 16015	Collar	4
5	Cap 17006	Grub Screw M3x3	4
6	Cap 17028	Button Head Cap Screw M3x16	1

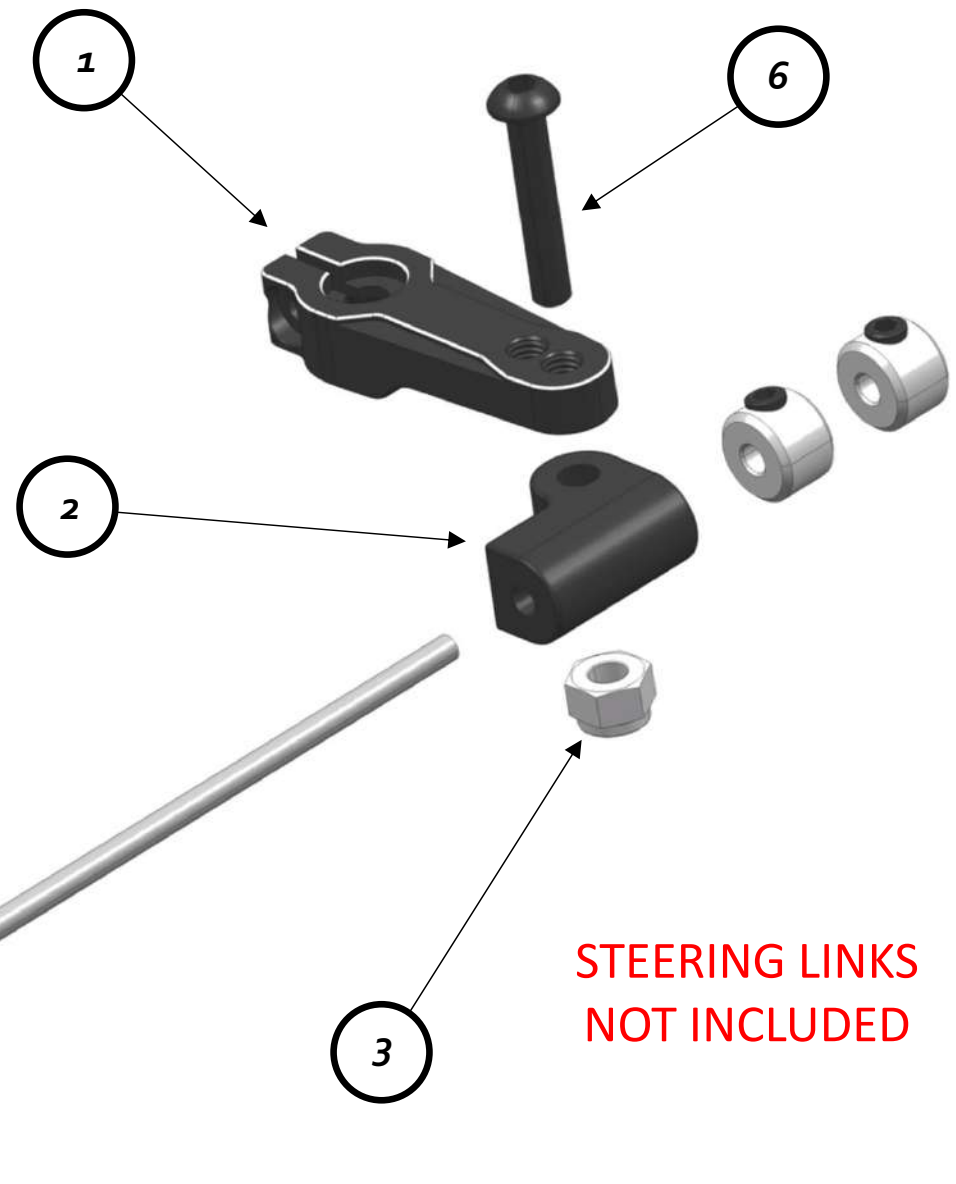

**STEERING LINKS
NOT INCLUDED**



BRAKE & THROTTLE LINKS MOUNTING



#	Code	Part Name	Qty
1	Cap 17030	Button Head Cap Screw M3x6	1
2	Cap 17026	Button Head Cap Screw M3x12	1

LEFT BRAKE & THROTTLE LINK

2

1

RIGHT BRAKE LINK

STEERING LINKS NOT INCLUDED



CASTER POSITION	SHORT WHEELBASE CONFIGURATION		LONG WHEELBASE CONFIGURATION	
	APPROX. CASTER [°]	APPROX. WHEELBASE [mm]	APPROX. CASTER [°]	APPROX. WHEELBASE [mm]
1	/	/	6.0	515
2	/	/	8.5	513
3	/	/	11.0	511
4	/	/	13.5	509
5	6.0	506	/	/
6	8.5	504	/	/
7	11.0	502	/	/
8	13.5	500	/	/

CASTER POSITION

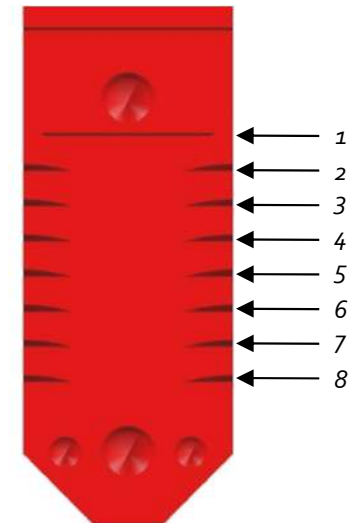

WHEELBASE CONFIGURATION

